



*An Online PDH Course
brought to you by
CEDengineering.com*

Underwater Bridge Repair, Rehabilitation, and Countermeasures

Course No: S11-001

Credit: 11 PDH

Gilbert Gedeon, P.E.



Continuing Education and Development, Inc.

P: (877) 322-5800

info@cedengineering.com

www.cedengineering.com

This course was adapted from the US Department of Transportation - Federal Highway Administration, Publication No. FHWA-NHI-10-029, “Underwater Bridge Repair, Rehabilitation, and Countermeasures”, which is in the public domain.

TABLE OF CONTENTS

CHAPTER I	UNDERWATER REPAIR AND REHABILITATION OF BRIDGES AND STRUCTURES	1-1
SECTION 1.	INTRODUCTION	1-1
1-1.1	Purpose	1-1
1-1.2	Background	1-1
1-1.3	Scope	1-1
CHAPTER II	MAINTENANCE	2-1
SECTION 1.	INTRODUCTION	2-1
2-1.1	Marine Environment Factors	2-1
2-1.2	Deterioration Models	2-3
2-1.3	Preventive Maintenance Activities	2-5
2-1.4	Performance Monitoring	2-6
CHAPTER III	UNDERWATER REPAIR PLANNING DATA AND REPAIR OPTION ANALYSIS	3-1
SECTION 1.	INTRODUCTION	3-1
SECTION 2.	CONDITION ASSESSMENT	3-1
3-2.1	General	3-1
3-2.2	Steel	3-1
3-2.3	Timber	3-2
3-2.4	Masonry	3-2
3-2.5	Scour	3-3
3-2.6	Concrete	3-3
SECTION 3.	STRUCTURAL ANALYSIS	3-6
3-3.1	Introduction	3-6
3-3.2	Piles	3-6
3-3.3	Undermining	3-7
3-3.4	Concrete	3-7
SECTION 4.	REPAIR STRATEGY	3-8
CHAPTER IV	MARINE CONSTRUCTION MATERIALS	4-1
SECTION 1.	INTRODUCTION	4-1
SECTION 2.	STEEL	4-1

	4-2.1	General	4-1
SECTION 3.		CONCRETE	4-3
	4-3.1	Mix Design	4-3
	4-3.2	Reinforcing	4-5
SECTION 4.		MASONRY.....	4-6
	4-4.1	Stone	4-6
	4-4.2	Mortar	4-6
SECTION 5.		TIMBER	4-6
	4-5.1	Preservatives.....	4-7
	4-5.2	Decay Reinforced Species	4-7
	4-5.3	Fabrication	4-7
SECTION 6.		COMPOSITES.....	4-8
	4-6.1	Components	4-8
	4-6.2	Physical Properties.....	4-8
	4-6.3	Mechanical Properties	4-8
	4-6.4	Example Products	4-9
CHAPTER V		UNDERWATER REPAIRS	5-1
SECTION 1.		INTRODUCTION.....	5-1
SECTION 2.		GENERAL CONSTRUCTION OPTIONS	5-1
	5-2.1	Repairs Performed “In-the-Dry”	5-1
	5-2.2	Repairs Performed “In-the-Wet”	5-1
SECTION 3.		ENVIRONMENTAL CONSIDERATIONS	5-2
	5-3.1	Site Conditions.....	5-2
	5-3.2	Water Conditions.....	5-2
	5-3.3	Regulatory.....	5-4
SECTION 4.		METHODS TO OBTAIN DRY WORK CONDITIONS	5-5
	5-4.1	Traditional Cofferdams	5-5
	5-4.2	Dikes.....	5-6
	5-4.3	Proprietary Barrier Systems.....	5-6
	5-4.4	Limpet Cofferdams.....	5-7
CHAPTER VI		EQUIPMENT FOR UNDERWATER REPAIR	6-1
SECTION 1.		INTRODUCTION.....	6-1
SECTION 2.		DIVING SYSTEMS.....	6-1
	6-2.1	Scuba	6-1

	6-2.2	Surface Supplied Diving.....	6-1
SECTION 3.		REMOTELY OPERATED VEHICLES (ROV)	6-2
SECTION 4.		ABOVE WATER SUPPORT	6-2
SECTION 5.		UNDERWATER TOOLS.....	6-2
SECTION 6.		EXCAVATION METHODS.....	6-5
	6-6.1	Hydraulic Excavators.....	6-6
	6-6.2	Airlifts.....	6-6
	6-6.3	Jetting	6-6
	6-6.4	Dredging	6-7
SECTION 7.		SPECIAL EQUIPMENT.....	6-7
SECTION 8.		UNDERWATER WELDING.....	6-8
	6-8.1	Introduction	6-8
	6-8.2	Methods.....	6-8
	6-8.3	Welding and Diving Standards and Specifications	6-9
	6-8.4	Effects of Wet Welding Versus Dry Welding	6-9
	6-8.5	Weld Design	6-10
	6-8.6	Weld Qualification	6-11
	6-8.7	Underwater Burning.....	6-12
CHAPTER VII		PIER REPAIRS	7-1
SECTION 1.		INTRODUCTION.....	7-1
SECTION 2.		FORMING SYSTEMS.....	7-1
	7-2.1	Rigid Formwork	7-1
	7-2.2	Flexible Formwork	7-2
	7-2.3	Concrete Preparation	7-2
SECTION 3.		REINFORCING	7-3
	7-3.1	Design Considerations.....	7-3
	7-3.2	Surface Preparation.....	7-3
	7-3.3	Anchorage	7-3
SECTION 4.		CONCRETE PLACEMENT METHODS	7-4
	7-4.1	Hand Patching.....	7-4
	7-4.2	Tremie Placement.....	7-4
	7-4.3	Pump Placement.....	7-5
	7-4.4	Preplaced Aggregate Concrete	7-6
	7-4.5	Bottom Dump	7-7
	7-4.6	Bagged Concrete.....	7-8

SECTION 5.	CRACK REPAIR	7-8
	7-5.1 Routing and Sealing	7-8
	7-5.2 Epoxy Injection	7-8
SECTION 6.	MASONRY REPAIR	7-10
SECTION 7.	UNDERMINING AND LOCAL SCOUR REPAIRS	7-11
	7-7.1 Undermining Repairs.....	7-11
	7-7.1.1 Grout Bags.....	7-12
	7-7.2 Scour Countermeasures.....	7-14
	7-7.2.1 Riprap	7-14
	7-7.2.2 Grouted Riprap	7-15
	7-7.2.3 Articulated Blocks	7-15
SECTION 8.	FOUNDATION MODIFICATIONS.....	7-16
	7-8.1 General	7-16
	7-8.2 Pile Installation.....	7-16
	7-8.3 Footing or Pile Cap Extensions	7-17
CHAPTER VIII	PILE and SHEET PILE REPAIRS	8-1
SECTION 1.	INTRODUCTION.....	8-1
SECTION 2.	PILE REPAIR.....	8-1
SECTION 3.	PILE REPLACEMENT	8-3
SECTION 4.	PARTIAL REPLACEMENT	8-4
SECTION 5.	PILE WRAPS.....	8-5
	8-5.1 Description and Purpose.....	8-5
	8-5.2 Advantages and Disadvantages	8-5
	8-5.3 Design Considerations.....	8-6
	8-5.4 Installation	8-7
SECTION 6.	PILE JACKETS.....	8-9
	8-6.1 Description and Purpose.....	8-9
	8-6.2 Advantages and Disadvantages	8-9
	8-6.3 Design Considerations.....	8-9
	8-6.4 Installation of Noncomposite Systems.....	8-10
	8-6.5 Installation of Composite Systems	8-13
	8-6.6 Quality Assurance	8-14
SECTION 7.	COMPOSITE STRENGTHENING	8-16
	8-7.1 Materials and Properties	8-16
	8-7.2 Installation	8-16
SECTION 8.	CRACK INJECTION.....	8-17

SECTION 9.	COATINGS	8-17
SECTION 10.	SHEET PILE REPAIRS	8-18
	8-10.1 Corrosion.....	8-18
	8-10.2 Damage Repair.....	8-19
CHAPTER IX	CATHODIC PROTECTION FOR SUBSTRUCTURES	9-1
SECTION 1.	INTRODUCTION.....	9-1
SECTION 2.	FUNDAMENTALS OF CATHODIC PROTECTION	9-1
SECTION 3.	CATHODIC PROTECTION SYSTEMS	9-2
	9-3.1 Galvanic Systems.....	9-2
	9-3.2 Impressed Current Systems	9-3
SECTION 4.	EXAMPLE SYSTEMS	9-4
	9-4.1 Pile Jacket-Anode Systems.....	9-4
	9-4.2 Surface Applied Systems	9-5
	9-4.2.1 Arc Sprayed Zinc.....	9-5
	9-4.2.2 Titanium Mesh System	9-5
	9-4.2.3 Zinc Sheets	9-6
	9-4.3 Embedded Anode Systems.....	9-6
	9-4.3.1 Impressed Current Systems	9-6
	9-4.3.2 Galvanic Systems	9-6
CHAPTER X	CONTRACTING AND CONSTRUCTION INSPECTION	10-1
SECTION 1.	INTRODUCTION.....	10-1
SECTION 2.	CONTRACTOR RISK.....	10-1
SECTION 3.	INSURANCE.....	10-1
	10-3.1 Worker’s Compensation	10-2
	10-3.2 Longshoreman’s Insurance	10-2
	10-3.3 Jones Act Maritime.....	10-2
SECTION 4.	CONTRACT DOCUMENTS AND ADMINISTRATIVE	10-2
	10-4.1 Drawings and Specifications	10-3
	10-4.2 Diving Submittals.....	10-3
	10-4.3 Prequalifications and Safety	10-4
SECTION 5.	PERMITS	10-5
	10-5.1 General	10-5
	10-5.2 Owner Provided.....	10-5
	10-5.3 Contractor provided.....	10-5

SECTION 6.	PAYMENT.....	10-5
	10-6.1 Unit Prices.....	10-5
	10-6.2 Mobilization and Demobilization	10-6
SECTION 7.	CONSTRUCTION INSPECTIONS	10-7
	10-7.1 Inspection Options.....	10-7
	10-7.2 Inspection Scope.....	10-8
	10-7.3 Above Water Inspection	10-8
	10-7.4 Inspection Checklists.....	10-9
	10-7.5 Acceptance Inspection and NBI Update	10-10
GLOSSARY	Appendix-1	
ACRONYMS	Appendix-13	

CHAPTER I

UNDERWATER REPAIR AND REHABILITATION OF BRIDGES AND STRUCTURES

SECTION 1. INTRODUCTION

1-1.1 Purpose

This manual is intended to serve as a reference for design engineers, construction inspectors, resident engineers, inspection divers and other administrative and technical staff whose work tasks include the design and construction administration of the repair or rehabilitation of elements of bridges or similar structures located below water. The manual addresses a variety of design and construction issues that must be considered in determining the feasibility of, and selecting the repair or rehabilitation methodology, for underwater projects. This information can aid in developing cost effective and durable repair and rehabilitation designs.

1-1.2 Background

Repairs to underwater bridge elements have been successfully completed for many years. However, the increased age of the nation's bridges and related structures, as well as the increased emphasis on regular underwater inspection since the revisions to the National Bridge Inspection Standards in 1988, indicates an increased need to perform repairs to elements located below or in water.

Information on design and construction of underwater repair and rehabilitation can be found in various reference documents. However, most of this information is in conference proceedings and journals outside the bridge engineering field and is often project specific. In an effort to better support the needs of bridge owners, in 1998 the Federal Highway Administration (FHWA) developed Demonstration Project 98, "Underwater Evaluation and Repair of Bridge Structures" (DP98) and made it available to state agency staffs and others in the bridge community. The present Manual is modeled on the DP98 content, but reflects changes in the industry over the past decade and expands on the previous course presentations.

1-1.3 Scope

The scope of this Manual is to provide information that is required in order to determine how underwater repairs may best be completed and to develop effective repair designs and specifications. It also gives guidance to construction inspectors to assure proper execution of underwater repairs.

The Manual does not address structure inspections and deterioration. Information in these areas can be found in FHWA publication “Underwater Bridge Inspection.” Furthermore, though diving is the primary access method for performing underwater construction in-the-wet, this Manual does not address diving. Diving information can be found in various references, and commercial diving activities must conform to applicable state and federal regulations.

The field of underwater construction, including repair and rehabilitation, is very dynamic. Innovative equipment, new techniques, and new materials are continuously being developed. Those working in this area are encouraged to attend conferences and read journals in order to avail themselves of these developments.

CHAPTER II MAINTENANCE

SECTION 1. INTRODUCTION

Maximizing the usable life of the nation's bridge inventory and related structures requires the effective application of preventive maintenance actions. In addition to the potential cost savings achievable by such activities, significant environmental benefits are realized when structures need not be demolished and reconstructed.

Preventive maintenance is defined by the AASHTO as "the planned strategy of cost effective treatments to an existing roadway system and its appurtenances that preserves the system, retards further deterioration, and maintains or improves the function condition of the system without increasing structural capacity." Crack sealing, joint repair, seismic retrofit, scour countermeasure installation, and painting are examples of preventive maintenance activities.

Confusion often arises between preventive and routine maintenance. Routine maintenance is defined "as maintenance work that is planned and performed on a routine basis to maintain and preserve the condition of the highway system or to respond to specific conditions and events to restore the highway system to an adequate level of service." Litter pickup, removal of material that might otherwise clog drains, snow removal, removal of roadkill, and removal of graffiti are examples of routine maintenance activities.

The Safe, Accountable, Flexible Efficient Transportation Equity Act: A Legacy for Users (SAFETEA-LU) Technical Corrections Act, enacted June 6, 2008, changed the Federal Highway Bridge Replacement and Rehabilitation Program to the Highway Bridge Program and placed greater emphasis on the importance of proper, timely bridge preservation. The extension in 2008 of AASHTO sponsored Transportation System Preservation Technical Services Program (TSP-2) to include bridge preservation is another indicator of the importance placed on maintenance activities.

Structures located in water are subject to added deterioration, and this is even more severe in a marine (coastal) environment with its ready availability of chlorides. An in-depth treatment of marine deterioration rates is beyond the scope of this Manual; however, some guidance is included. Use of available inspection reports and agency experience of structure deterioration types and rates for local conditions is important in developing a preventive maintenance program.

2-1.1 Marine Environment Factors

Structures located in water can be subject to rapid deterioration of their in-water elements such as piles and piers. Freezing and thawing effects, sulfate attack, and

corrosion of steel and reinforcing—particularly in salt water—are representative of marine deterioration types whose extent and rate of progress are affected by local environmental factors. The effect on marine structures of the more significant environmental factors is shown in Figure 2-1. The local combined effects of wind, temperature, and water generally control the deterioration rate of any given structure. Good design, construction, and maintenance can mitigate the extent and rate of deterioration.

Environmental Conditions	Effect on Deterioration Rates
Water temperature	Warm waters accelerate chemical reactions such as corrosion. However, warm water usually results in increased marine fouling, which may inhibit corrosion.
Oxygen content	Increased oxygen content of the water promotes corrosion. Wave action, turbulence, water flow rate bring oxygen to the submerged elements.
Water pH	Acid waters, low pH, accelerate corrosion and can result in deterioration of concrete materials.
Salinity	Chlorides from salt facilitate corrosion. Sea water has a salt content of approximately 3.5 percent. Corrosion rates are generally observed in brackish water with salt contents around 1 percent
Sulfates	Sulfates in sea water produce concrete deterioration.

Figure 2-1 Effects of Environmental Conditions on Deterioration Rates

The deterioration of elements in water is related to the exposure zones along the member as shown in Figure 2-2. The most rapid deterioration occurs in the splash zone due to the ready availability of moisture and oxygen. The tidal zone, or zones of seasonal water level variation, also experience corrosion rates higher than the atmospheric or submerged zones. These zones are often critical for concrete and steel construction. Areas fully submerged generally see reduced corrosion due to the lower availability of oxygen. Unlike concrete and steel construction, the critical deterioration zone for timber construction extends over the full member length.

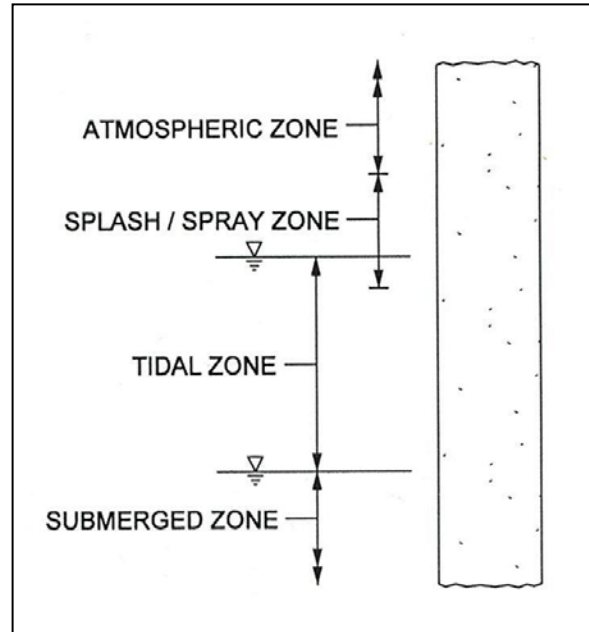

Figure 2-2 Exposure Zones

2-1.2 Deterioration Models

In order to determine the most cost-effective methods to retain a structure in service, both its existing condition and its expected rate of future deterioration need to be considered. The timely application of preventative maintenance can extend the life of the structure by preventing critical defects to form. This is shown graphically in Figure 2-3. Application of this approach requires a well defined minimum level of performance, and the ability to predict the rate of deterioration.

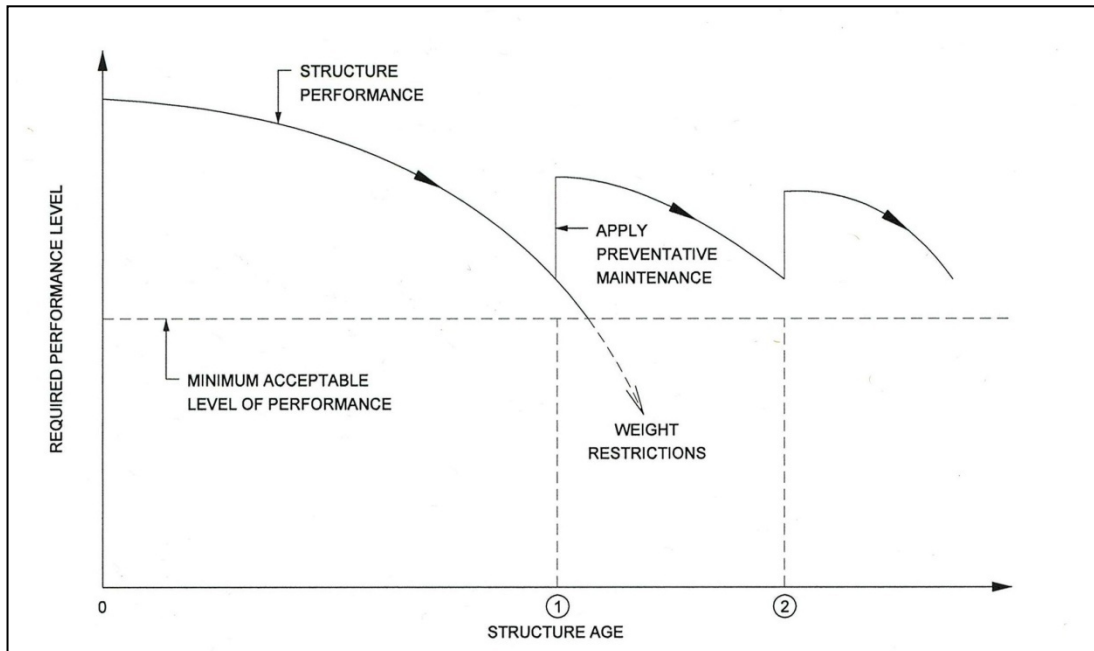

Figure 2-3 Effect of Maintenance

For bridges, the minimum level of performance should at least be such that no reduction of live load capacity occurs. Load ratings should be developed from current bridge inspection data.

Estimating rates of deterioration can utilize several approaches. Rates of deterioration are often estimated from past experience with structures of similar type and exposure. A review of the changes in bridge structure inspection data can also provide a means of estimating expected future deterioration. Plots of changes in condition rating with time can be extrapolated to predict at what point critical conditions might be reached and then select when preventive maintenance is needed.

Figure 2-4 provides a graphical representation of the progress of concrete deterioration due to corrosion. At sometime after completion of construction, T_i , conditions at the reinforcing steel develop that initiate corrosion. As corrosion continues, a point is reached where corrosion products build up, and resulting surface cracking appears, T_s . The cracks allow the corrosion process to accelerate.

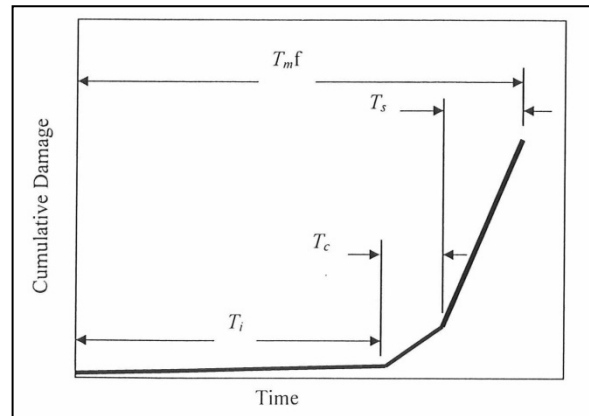

Figure 2-4 Concrete Deterioration Due to Corrosion

Reinforcing steel corrosion leads to further cracking and spalling of concrete until extensive repairs are required to restore the structure. The actual time for these stages to be reached in a given structure depends upon numerous factors such as concrete permeability, cover depth, and chloride content. For preventive maintenance to be most effective it must be applied prior to reaching time T_1 .

Steel corrosion losses for piles can be estimated from tables and charts of corrosion rates located in various references. Typical corrosion rate data for carbon steel sheet piling in sea water is shown on Figure 2-5. Additional information on steel corrosion rates in fresh, polluted, and sea water is presented in Chapter 4.

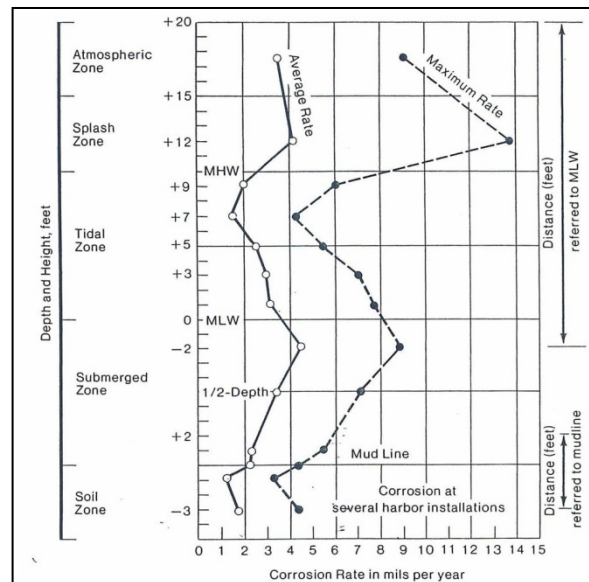

Figure 2-5 Corrosion Rate in mils per year

Deterioration rates can also be determined analytically utilizing field and laboratory materials test information and computer models such as Life 365[®] and Stadium[®] for reinforced concrete structures. Additional information is available from the Transportation Research Board and the Strategic Highway Research Program. Due to the extent of test data required to provide accurate results from such models, their use tends to be limited to large structures. However, they could also be used to develop more general data applicable to a population of similar (i.e., age, location, visual inspection results) structures.

2-1.3 Preventive Maintenance Activities

As discussed above, preventive maintenance includes applying a variety of measures to inhibit further deterioration and extend the useful life of the structure. Though major repairs or rehabilitation also provide these functions, preventive maintenance activities are normally lower cost and often applied at regularly established intervals. Typical bridge substructure maintenance activities include protective coatings, crack sealing, local repairs such as patching, and the installation of pile wraps and jackets.

Coatings provide a barrier between the water and the surface of the structural member to inhibit corrosion. The application of coatings is widely used on steel members, generally applied prior to installation. Though coatings can be applied to concrete members, this is not commonly used. Similarly, coatings are not typically used on timber members. For uncoated structures, or where an existing coating has been damaged or is deteriorated, field applied coatings are available. When considering application of coatings to concrete elements, the potential for the coating to debond due to trapped water vapor pressure must be considered.

Coatings for field application in the splash zone and below water are specially formulated, and are typically epoxy or polyester based products. Their manufacturers should certify that the formulations are environmentally acceptable in the intended application. Prior to application, substrates must be properly prepared, and all residue or debris properly disposed of. In some locations proper surface preparation may be impractical to perform within environmental constraints. For instance, high pressure water cleansing or abrasive blasting may cause unacceptable dispersion of old coatings into the waterway.

Splash zone and underwater coatings are applied by gloved hand, brush, roller, or possibly special applicator systems, unless the areas are located within cofferdams. The lifespan of these coatings should be carefully considered as their lifespan will not match coatings applied in dry conditions. Abrasive blasting to clean the surface and provide a surface profile for coating adhesion is essential for proper coating performance.

A major contributor to the deterioration of reinforced concrete is the presence of cracks which allow increased penetration of chloride contaminated or salt water to the reinforcing steel. Sealing cracks which were not corrosion generated will reduce

chloride penetration and may delay the onset of reinforcing corrosion. Examples of these cases include pile cracks due to improper installation, volume change cracks in pier shafts, and cracks resulting from impact damage. Where the existing cracks are the result of the expansive forces of corroding reinforcing, sealing of the cracks will not markedly effect the continued corrosion of the steel as by that point the concrete surrounding the reinforcing is already chloride saturated. Sealing of such cracks with a flexible sealant may reduce the rate of corrosion by inhibiting oxygen access and new chlorides, but continued corrosion will occur. The use of rigid sealants at corrosion cracks should be discouraged as a new crack can be expected to develop close to the crack “glued” by the epoxy.

Local patching repairs to concrete structures can be used to reduce the exposure of cracked or spalled areas to further corrosion. When applied to local areas of impact damage such repairs are effective in limiting further deterioration. Where local deterioration is due to chloride induced corrosion, localized patching may be of limited benefit. This is because the development of corrosion induced deterioration indicates the concentration of chlorides at the level of the reinforcing has already exceeded the corrosion threshold value (approximately one and one-half pounds of chlorides per cubic yard). Even if patch repairs remove this contaminated concrete around the reinforcing in the deteriorated area, adjacent areas of concrete at or near the critical chloride threshold remain such that future deterioration of areas adjacent to the local repairs can be expected. Methods for reducing these effects are discussed in chapter IX, Cathodic Protection for Substructures. Cathodic protection can be used to effectively halt further corrosion of both reinforced concrete and steel members.

Application of pile wraps and jackets may be considered preventive maintenance activities if their installation is programmed such as to limit the ingress of chlorides to prevent their reaching threshold values, or stop teredo or limnoria damage to timber piles prior to significant damage accumulation. Whether utilized as a maintenance measure or a repair, selection and installation are very similar. Installation of wraps and jackets is addressed in chapter VIII, Pile Repairs.

Removal of debris accumulations from around piers and abutments reduces lateral loads to the structure and also aids in reducing the local scour effects of the debris. A scheduled program of removal would constitute a preventive maintenance measure. The installation of debris shields or other devices to keep debris from accumulating are other preventive measures.

Many maintenance actions are similar to repairs, except for their timing and extent, and the relevant chapters can be utilized for their selection and installation.

2-1.4 Performance Monitoring

Regular monitoring of a structure’s performance or condition must be part of a planned program of preventive maintenance since it is the basis of determining what preventive measures are appropriate and when they should be applied. While normal

bridge condition inspections are an initial source of information, interim inspections may be appropriate for structures with known deficiencies. It is important that in service inspections closely examine any in place maintenance and repair measures to assess their performance.

Monitoring activities may incorporate the installation of real-time sensors and gauges. Such instrumentation can be installed prior to the onset of deterioration in order to detect when certain parameters such as chloride levels, crack widths, or corrosion activity has reached preset values. A crack gauge applied to a footing below water is shown in Figure 2-6.

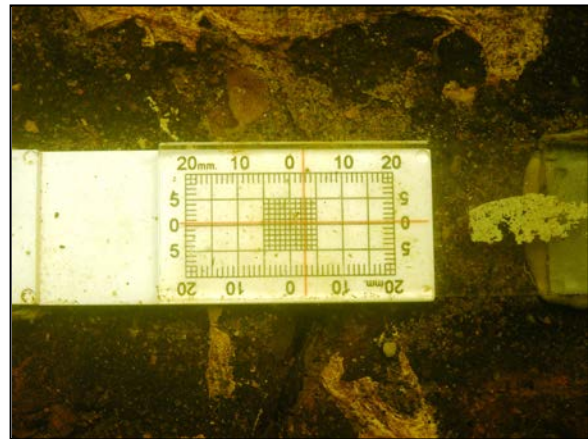

Figure 2-6 Crack Gauge

When critical levels are reached, previously programmed maintenance activities are initiated. Where maintenance or repairs are performed, the inclusion of monitoring systems within the repairs provides information both on overall structure performance and on the performance of the repair itself. Little information is available on the actual performance of in water and underwater repairs. Data accumulated by instrumentation incorporated into the repair or by detailed periodic performance inspections can provide valuable information for use in optimizing the selection and design of various maintenance and repair activities.

Monitoring data should be evaluated for its reasonableness and consistency. Plotting the data on a time basis can allow an estimate of the life expectancy of the remedial measures. Data can be monitored continuously or at set intervals utilizing automated systems with wireless communications. The monitoring systems can be set to pre-established performance measures, whose exceedance automatically initiate preplanned maintenance, inspection, or other measures.

Field instrumentation installed on marine substructures should be carefully designed and installed to withstand the environmental conditions. Locations for field readings should preferably be assessable without the use of boats. Instrumentation sometimes used to monitor bridge substructures includes scour monitoring devices and tiltmeters or inclinometers.

CHAPTER III UNDERWATER REPAIR PLANNING DATA AND REPAIR OPTION ANALYSIS

SECTION 1. INTRODUCTION

The first step in developing a repair or rehabilitation project, whether above or below water, is to review available condition data and determine both the effect of the damages as well as the underlying deterioration mechanisms. This process should begin with a review of pertinent information including design, as-built, and repair drawings; inspection reports; scour reports; and any additional information related to changes in the structure or waterway since the original construction. Based on this information, a condition assessment can be performed to identify the extent of any distress and determine the causation. Information on underwater inspections is located in the FHWA publication "Underwater Bridge Inspection Manual."

Using the results of the condition assessment, a structural analysis should be performed to determine the existing capacity of the structure and to determine the extent of repairs required. Once these are established, an effective repair strategy can be developed. The repair strategy must address any material and structural deficiencies and restore the structural integrity of individual members and the bridge substructure units as a whole. In addition, the repairs should also be developed with consideration of the economic effects.

SECTION 2. CONDITION ASSESSMENT

3-2.1 General

The modes of deterioration and extent of distress must be identified during the condition assessment. Deterioration of structural components may be due to material deterioration as well as physical damage from vessel impact, ice, floating debris, scour, seismic or flood events, and similar occurrences. Information on various deterioration mechanisms is presented in the "Underwater Bridge Inspection Manual" and will only be briefly summarized in this manual. While concrete is the predominant substructure material currently utilized in bridges, foundations of steel piles, timber piles and cribbing, and masonry are common.

3-2.2 Steel

Steel deterioration results from corrosion which reduces the members' sectional area (Figure 3-1). Corrosion is primarily a concern for piles located in salt or brackish water, or in waters containing pollutants that are acidic. Corrosion in fresh water is normally minimal except for areas of microbially induced corrosion. Physical damage

due to impact or seismic events can result in member deformation and in extreme cases, cracking or fracture.

Visual and tactile inspections (Level I and Level II inspections) of steel structures can typically identify areas of localized corrosion. However, more extensive non-destructive testing (Level III inspection) must be conducted to determine the thickness of steel material remaining in a member. The most common method of obtaining this information is by using ultrasonic testing equipment.

3-2.3 Timber

Timber members are susceptible to rot and insects, as well as limnoria and teredo attack (Figure 3-2) if located in sea water. Physical damage includes cracking and splitting as well as abrasion resulting from ice, debris, or abrasive sediments carried in the flow.

Visual and tactile inspections (Level I and Level II inspections) of timber structures can typically identify areas of decay and physical damage. More extensive testing (Level III inspection) must be conducted to determine the presence of marine organisms and to identify internal deterioration. These deterioration mechanisms can be detected by taking timber cores or by utilizing ultrasonic testing equipment.

3-2.4 Masonry

Deterioration of masonry structures includes weathering of stone or brick and erosion of mortar from joints (Figure 3-3). Physical damage can include spalling, cracking and even loss of stones or brick.



Figure 3-1 Steel Deterioration Resulting from Corrosion



Figure 3-2 Damaged Timber

3-2.5 Scour

Foundations located in moving water are subject to the effects of scour. This can result in undermining of spread footings and pile caps (Figure 3-4), and increased exposed lengths of piles in pile bents or of shafts. Chapter VII further addresses issues of local scour effects and countermeasures.

3-2.6 Concrete

Deterioration of saturated concrete due to cycles of freezing and thawing can occur in structures exposed to water and temperatures below freezing (Figure 3-5). Freezing of water in the pores of concrete can give rise to concrete stresses that can rupture the cement paste.

Concrete that is continuously submerged will usually perform well with deterioration primarily in areas subject to wetting and drying.

Investigations have shown that the rate of deterioration due to freezing and thawing is considerably higher in salt water than in fresh water. This difference in resistance to freezing and thawing is normally ascribed to the generation of a higher hydraulic pressure in the pore system due to salt gradients and osmotic effects. Small air voids in the concrete will become water-filled after a long period of immersion. These voids may also be more easily filled when salts are present. In spite of the lower frost resistance of concrete in salt water, deterioration normally takes place very slowly.

Damage due to salt scaling can affect portions of concrete in marine environments located in the splash zone. When water with dissolved salts splashes onto the structure, some of it migrates into the concrete through cracks, surface voids, pores, and capillaries. As the concrete dries, the salt solution is concentrated and eventually



Figure 3-3 Deteriorated Masonry



Figure 3-4 Undermining of Footings



Figure 3-5 Deteriorated Concrete

crystals form. When the salt then changes to a higher hydrate form, internal pressure results, and the concrete disintegrates just beneath the surface.

Corrosion occurs when chlorides of varying concentrations such as are present in salt or brackish water penetrate the concrete, and upon reaching the reinforcing steel set up electrochemical reactions that corrode the reinforcing steel. Corrosion products occupy several times the volume of the original metal and develop internal pressures, creating a stress greater than the tensile strength of the concrete. Cracks form along the reinforcing bars, and eventually the concrete cover spalls (Figure 3-6). This allows exposure to increased chlorides, and causes corrosion of the steel reinforcement to accelerate.



Figure 3-6 Cracks Along Reinforcing Bars

Symptoms of corrosion include concrete cracking orientated parallel to the reinforcing, spalling over reinforcing, and rust staining.

Steel in concrete is normally protected chemically by the alkalinity of the concrete. This is due to a passivating film that forms on the surface of embedded reinforcement and provides protection against corrosion. Greater depth of cover and less permeable concrete provide increased resistance to the ingress of chloride ions, which compromise the passivating film.

The entry of the electrolytes and oxygen are facilitated in more permeable concrete. Water containing dissolved salt provides an electrolyte of low electrical resistivity, thus permitting corrosion currents to flow readily. Oxygen is essential to the electrochemical reaction at the cathode of the corrosion cell. Consequently, steel in reinforced concrete completely and permanently immersed in water corrodes much more slowly than in splash zones because the oxygen supply is greatly reduced. Wave action or other activities that mix the upper water surfaces may produce oxygen sufficient to support corrosion below the normal water levels.

A severe exposure condition exists when part of the concrete structure is alternately wetted by salt water, as by tides or sea spray. The part that is alternately wetted has ample opportunity for contact with atmospheric oxygen. For this reason, reinforcing steel in concrete in aqueous environments corrodes faster in the tidal zone and spray areas than in other areas.

Concrete may also deteriorate due to reactions that can take place between the constituents of the concrete. Typically, reaction products develop that occupy a volume greater than the original solid materials, resulting in increased concrete stresses and cracking. The most common of these internal reactions is the alkali-silica

reaction. In this case, the alkalis present, primarily in Portland cement, react with silica found in certain aggregates. The reaction gel expands when it is moistened causing tensile stresses in the concrete. Alternating wetting and drying frequently associated with the aquatic splash zone accelerates this reaction. Also, salt in marine environments can accelerate alkali-aggregate reactions by increasing the sodium ion concentration until it is above the minimum level necessary for alkali reactivity. Symptoms of alkali-aggregate attack are map or pattern cracking and swelling of the concrete. In prestressed piles the horizontal cracks in the map cracking may not be visible due to the precompression in the concrete.

Failure of precast prestressed piles attributed to delayed ettringite formation (DEF) has been reported, primarily on the west coast. Presently, this deterioration is attributed to improper high temperature curing practices in manufacturing. Concrete distress due to delayed ettringite formation is characterized by cracking and softening of the concrete along with loss of concrete (Figure 3-7). Observed deterioration has included near total loss of concrete over substantial portions of affected piles.



Figure 3-7 Failed Precast Prestressed Pile Due to Delayed Ettringite Formation

Sulfates of sodium, potassium, calcium, or magnesium are often found in sea water, ground water, rivers, and industrial water. The chemical reactions that take place between sulfate ions and Portland cement result in reaction products that have a greater volume than the reactants. This volume change causes the development of stresses in the concrete that eventually lead to cracking and deterioration. Symptoms of sulfate attack include map cracking and softening of the concrete. In prestressed piles, observed cracking is primarily vertical as the prestress force tends to close the horizontal cracks.

Concentrations of magnesium ions present in some ground water and in seawater may be sufficient to react with the calcium silicate hydrate, replacing calcium ions with magnesium. When this reaction occurs, there is a reduction in the amount of calcium silicate hydrate present in the cement matrix which leads to a reduction in the strength of the cementitious material and a softening of the exposed surface. Splash zone concrete is especially susceptible to sulfate and magnesium ion attack due to the frequent wetting and drying cycles cause by wave or tidal action. This action washes away soft outer layers and replenishes the supply of aggressive chemicals.

Deterioration of concrete may be accelerated by deficient practices during initial construction or repair. These include:

- Exceeding specified water-cement ratios
- Poor placement and consolidation
- Inadequate reinforcing cover
- Poor surface preparation
- Construction damage to coated reinforcing
- Improper pile driving practice

Improper pile driving can produce tension cracking. This problem is characterized by horizontal cracks generally occurring in the below-water portion of the pile. Both underwater and in the splash zone, cracks in concrete increase concrete permeability near the crack. Thus, in sea water, chloride penetration is amplified both in depth and concentration in the immediate location of the crack, leading to the creation of an anode at the reinforcing bars. This usually does not lead to significant corrosion of steel reinforcement in underwater concrete because of the low oxygen availability and sealing of the crack by lime, which leaches from the concrete and from the deposition of marine organisms. In the splash zone, however, the existence of such cracks can lead to the early onset of local reinforcing steel corrosion, due to the presence of oxygen and cracks that are unable to seal from the wave action.

Visual and tactile inspections (Level I and Level II inspections) of concrete structures can typically identify the location of spalls, cracks, and delaminations. In addition, these inspections may also identify cracking patterns, soft surfaces, and disintegration. Additional testing (Level III inspection) may consist of removing cores and performing laboratory testing and petrographic analyses. In most cases, Level III testing is performed on areas where internal deterioration is suspected. Coring concrete members when the observed cracking patterns do not appear related to corrosion or impact damage may be done as part of a Level III inspection. Testing on the cores may include a petrographic analysis to examine the possible affect of chemical attack such as alkali-aggregate reaction or delayed ettringite formation.

SECTION 3. STRUCTURAL ANALYSIS

3-3.1 Introduction

Evaluating the affects upon the structure of deterioration or damage can be a difficult task. The engineer must decide whether the observed deterioration or damage affects the load carrying capacity of the component or structure, or is non-structural. A non-structural defect may affect appearance or reduce durability. Assessing the effects of physical member defects, often the result of a known event, is generally less difficult than assessing the effects of material deteriorations.

3-3.2 Piles

Selection of pile sizes may be controlled by structural requirements or geotechnical capacity. While deterioration and damage reduce the structural capacity, the

geotechnical capacity is not reduced unless scour effects cause a loss of embedment for piles designed to develop their load capacity through soil/pile friction (adhesion).

Where piles have suffered a loss in cross sectional area, the stresses should be calculated based upon the remaining area recognizing that the reduced area also reduces the pile radius of gyration and thus increases the effective pile length. For corrosion of steel H-piles, the resultant width-to-thickness ratio must also be evaluated for local buckling. Design of concrete piles is based upon the full cross section carrying load; thus corner spalls and loss of concrete outside the reinforcing do reduce pile capacity. Loss of reinforcing steel area due to corrosion has a greater affect on the pile bending capacity than on axial capacity. Timber piles may suffer reductions in section due to loss of exterior material, such as due to rot or limnoria attack, or interior material through borer activity or internal rot. Deterioration which affects the external dimensions is generally more significant than internal deterioration due to the greater effect on the reduction in the moment of inertia.

The location of deterioration or damage clearly affects its structural implications. While the axial load on a pile or shaft is constant along its height, moments, if present, are generally at their maximum near the mid-height or below. This means that the location of maximum losses, which are most often in the waterline region, may not occur at the location of maximum pile stresses. Deterioration and stress must be compared at intervals over the pile length.

3-3.3 Undermining

Undermining reduces the bearing area of spread footing as well as lateral restraint. Bearing pressures and lateral resistance in areas of undermining can be computed based upon field measurements. However, it is probable that at least the periphery of the remaining ground has had its soil strength properties reduced and so any computations should be made with great conservatism, especially considering the often catastrophic consequences of scour failures.

Scour will also increase the effective length of piles in pile bents or of exposed piles below pile caps. These conditions can be evaluated as noted for piles, above.

3-3.4 Concrete

Cracking in reinforced concrete members must be investigated to establish its cause, and whether the cracks are dormant or active. Cracking due to an impact (Figure 3-8) would be dormant, while corrosion induced cracks are active

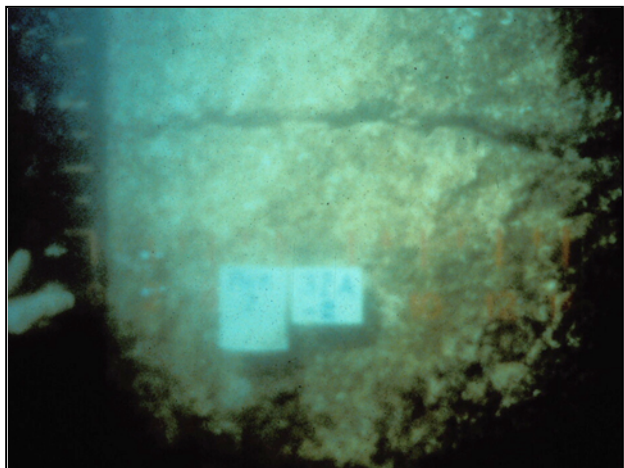

Figure 3-8 Cracked Concrete Member

unless the corrosion process is stopped. Cracking due to alkali-silica reaction is active until all of the reacting chemicals are utilized. Attempts to repair active cracks with patches or adhesives are generally ineffective as the mechanism which initially caused the crack continues, creating cracks elsewhere.

Corrosion of reinforcing steel affects concrete in several ways. These include:

- Loss of steel cross-sectional area to resist loads
- Spalling and cracking
- Loss of confinement due to tie corrosion
- Loss of bond due to concrete splitting

Cracking increases access for moisture and oxygen to reach the reinforcing and accelerates the corrosion process. The potential loss of bar anchorage or bond due to corrosion is illustrated in Figure 3-9, and can reduce beam or pier cap capacity. Figure 3-9 shows a beam with a crack extending along the bottom reinforcement. This cracking can reduce the bar anchorage, resulting in failure. In estimating the loss in capacity due to reinforcing corrosion, the extent of steel loss should be based on a conservative estimate of actual steel loss due to the variability of corrosion over a length of reinforcing, and local effects of pitting.

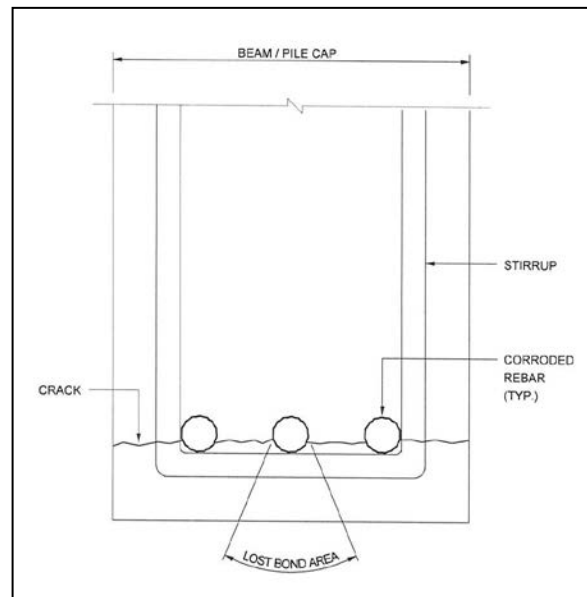

Figure 3-9 Bond Loss from Corrosion

Concrete deterioration due to internal chemical reactions can be very difficult to repair. When material problems are suspected, concrete samples should be obtained for laboratory analysis, generally including petrographic examination. This will allow the deterioration mechanism to be established, and for some types of deterioration, determine whether the reactions will continue or have ceased. The increased level of non-destructive testing and sampling sometimes necessary to accurately determine the extent of chemical/materials deterioration may require the construction of cofferdams or similar systems to properly access the substructure member.

SECTION 4. REPAIR STRATEGY

Repair strategies range from making an engineering decision to allow the conditions to continue with no action, to various levels of repair, and possibly replacement. Factors which influence the option chosen include:

- Extent of damage/deterioration
- Type of damage/deterioration
- Structure age
- Possible planned rehabilitation or replacement
- Estimated rate of deterioration
- Available funding
- Traffic effects, detours

Structures seldom have to be in perfect condition to perform adequately. Where the rate of deterioration is slow or the extent of deterioration limited, no action may be required. Where the existing conditions do not negatively affect structure safety, increased frequencies of inspection or installation of structure monitoring instrumentation might be used in order to better access the rate of deterioration determine when critical conditions have developed and establish an estimated time for repairs if needed.

When engineering analysis based upon documented conditions establishes that repair is necessary to restore structural capacity, or data shows a rate of deterioration such that critical conditions could readily occur, repairs or replacement are needed. In preparing repair designs it is critical that the cause of the distress first be established.

Often repairs are executed that respond to the effects of the distress rather than their cause. One example of this is the use of polymer injection to repair corrosion cracking. Such repairs do not address the cause of the distress, which is the chloride contaminated concrete at the reinforcing steel, and hence are predisposed to fail as corrosion continues.

Figure 3-10 shows a concrete pile during repair. The piles had previously been repaired by installing polymer pile jackets and grout. After approximately 20 years of service, an inspection disclosed loose jackets and spalling of the pile corners.

The repairs were to consist of pile jacket removal, corner repairs of the concrete pile, and the installation of new jackets. During concrete removal operations on this project, it was observed that all of the concrete could be removed using only hand tools. The original evaluation had not established the true existing conditions, and hence the repairs required redesign once they were under contract and the true extent of deterioration apparent. The original repairs for this project did not address the cause of the deterioration.



Figure 3-10 Concrete Pile During Repair

Repairs should not cause distress to adjacent portions of the structure. The case of using rigid sealants in an attempt to repair active cracks has been noted earlier. Another example of distress resulting from repair activities is anodic ring or “halo” corrosion of chloride contaminated concrete. Repair of corroded and spalled concrete distress caused by high levels of chlorides in the surrounding concrete typically consists of removing the damaged concrete and replacing it with new concrete. When this is done, the concrete surrounding the repaired area remains high in chloride content, and the reinforcing steel is then embedded in and runs between chloride free repair concrete and contaminated concrete. The interface areas experience a large local change in corrosion potential between the new and remaining concrete which accelerates corrosion at the boundaries of the repair, hence the term “ring corrosion.” Incorporating cathodic protection within the repair is one technique to mitigate this problem, and is discussed in Chapter IX.

Repairs are often required due to deterioration of the existing structure materials. In designing and specifying the repairs, materials and placement methods must be chosen that produce repairs with good long term durability so that the need for further repair is minimized. These aspects of repair will be presented under chapters dealing with materials and specific repair techniques.

Details of various repair techniques are given in later chapters of this manual, however good surface preparation is a requirement for all repair work. Surface preparation must remove marine growth, silt deposits, and other deleterious substances. Steel corrosion, rotted or soft timber, and deteriorated, spalled, or delaminated concrete must be removed in all areas to receive repair materials. Removal of concrete should extend behind all reinforcing steel in order to remove chloride contaminated concrete and allow the repaired concrete to be mechanically anchored. An allowance in removal quantities up to 20 percent is often included in cost estimates for removal beyond the area of visual distress.

Surface preparation in marine work is often performed in stages. Primary surface preparation is completed, and then just before placing repair material, a final cleaning is conducted. This allows rapidly accumulated silts and marine growth to be removed.

The extent of deteriorated material in some structures may be extensive. In these cases consideration should be given to limiting material removal to a depth that facilitates repair while eliminating the need for temporary shoring or near total component replacement. This is particularly practical for massive structures such as bridge piers. Placing limits on material removal also controls the overall extent of work, since the interpretation of “deteriorated” material may vary.

In developing repair schemes consideration should be given to the member surface conditions following cleaning. The resulting surfaces may be highly irregular such that preparatory work may be needed to allow proper fit-up of forms or pile jackets.

Repair of heavily corroded steel members by adding welded plates may likewise be impractical due to poor fit-up of meeting surfaces.

Access for repair crews to execute the repairs is usually by boat or barge. Sometimes the work area may be accessible from the bridge deck. Access may also be limited due to tides or currents. These conditions reduce the time available for executing repairs, and repair materials must accommodate the resultant transport and prolonged placement times.

Marine construction work is more costly than similar work performed on land. In addition to standard equipment required to undertake the repair work, marine construction requires boats, barges, or floats, and generally diving equipment not needed for similar on shore work. The work generally needs added support staff to handle boats and provide support for divers.

Productivity is reduced due to added weather constraints, possible environmental regulations that provide limited work windows, currents, tides, any nearby vessel traffic, and the travel time from a dock area to the work site. When dive work is conducted, the diver's productivity will be less than a comparable tradesperson on land. A single diver in the water requires at least two additional support crew members above water. Work in an over water, particularly when boats and crews are needed, requires specialized insurances which are very expensive. These are further discussed in Chapter X.

The several factors described above are primary contributors to the increased costs of marine construction and underwater construction. Cost estimates for marine work should be based upon an extensive agency cost data base and discussed with contractors when possible. Those persons responsible for cost estimates made to compare repair options or support contract documents must be well versed in the particular requirements of marine work.

CHAPTER IV MARINE CONSTRUCTION MATERIALS

SECTION 1. INTRODUCTION

A variety of construction materials may be used in the repair of bridge substructures in water. While most of the material properties important in new construction are applicable in repair projects, those properties related to durability and constructability are of particular importance. Many repairs are necessitated by material deterioration. Repair materials must be selected and specified to prevent a recurrence of the same problems and provide enhanced durability.

SECTION 2. STEEL

4-2.1 General

Steel and its properties are well known to bridge engineers. In substructures it is usually found as bearing piles. Sometimes steel pile bracing is located underwater and steel sheet piles are used for walls and bridge protective works. Steel piles and sheet piles may be installed as part of repair or rehabilitation projects. Long term durability for the piles requires taking measures to minimize steel losses due to corrosion. While piles placed in fresh water may have minor corrosion losses, those installed in brackish or salt water can be subject to rapid section loss. Various factors effecting section loss are discussed in the FHWA Underwater Bridge Inspection Manual. Figure 4-1, developed from the Eurocode, provides guidance on typical corrosion losses for steel piles located in water. These values apply to each exposed surface and must be used with consideration of local conditions and experience.

Required Design Working Life	5 yrs	25 yrs	50 yrs	75 yrs	100 yrs
Common fresh water (river, ship canal, etc.) in the zone of high attack (water line)	0.006	0.022	0.035	0.045	0.055
Very polluted fresh water (sewage, industrial effluent, etc.) in the zone of high attack (water line)	0.012	0.051	0.090	0.130	0.170
Sea water in temperate climate in the zone of high attack (low water and splash zones)	0.022	0.075	0.148	0.220	0.300
Sea water in temperate climate in the zone permanent immersion or in the intertidal zone	0.010	0.035	0.069	0.102	0.138

Figure 4-1 Loss of Thickness (in.) Due to Corrosion for Piles and Sheet Piles in Fresh Water or in Sea Water. Reference: Eurocode 3: Part 5

Steel piles are sometimes designed with a sacrificial thickness allowance, such that after the expected corrosion losses take place the resulting pile section properties are sufficient to support the required load. Common methods of protecting steel piles from corrosion along with their representative expected periods of protection are shown in Figure 4-2. Coal tar epoxy has been used as a pile coating for many years, but in some locations it is no longer permitted due to environmental concerns. Oregon has used a 3 mil zinc rich prime coat with two 4 mil top coats of a urethane for some pipe piles, and other paint systems are available.

Coating Description	Period of Protection
Coal tar epoxy (15 to 20 mils thickness)	10 - 20 years
Galvanizing (7 to 9 mils thickness)	10 - 15 years
Metalized Aluminum	15 - 20 years
Concrete Encasement	25 years

Figure 4-2 Period of Protection for Steel to be Expected from Various Coating Systems of Common Use (Marine Exposure). Reference: Unified Facilities Criteria, UFC 4-151-10

Hot dipped galvanized piles have been used by the Alaska DOT and others. Galvanized coatings on piles are usually 7 to 9 mils thick, which exceeds that which would be provided under AASHTO Specification M111. Achieving galvanized thickness with 7 to 9 mils requires control of the silicone content in the base metal. Metalizing with aluminum to achieve a 6 to 12 mil coating thickness can also be used. The aluminum provides a protective system similar to galvanizing. Both galvanized and aluminized piles can be top coated with a paint system for added protection and appearance.

Pile coatings normally extend from the top of the pile to five feet below the riverbed, though the full length of the pile can be coated if the bottom soils are considered to be aggressive. Coatings are shop applied in accordance with the specific coating manufacturer's requirements. Shipping and site handling of coated piles must be performed so as not to damage the coating. Field touch-up to any coating defects should be done just prior to pile installation.

Fusion bonded epoxy coatings have also been used as corrosion protection. A coating thickness of 7 to 9 mils is commonly specified.

Concrete encasement of piles is not widely used in present practice, but can provide very good protection. The encasing concrete must be durable and should contain reinforcing steel for temperature and shrinkage control of the encasement.

Steel can also be protected by installation of cathodic protection systems. This is discussed in Chapter IX.

SECTION 3. CONCRETE

Concrete is the most common material used for construction of bridge substructures. It is also a primary repair material for repair of concrete as well as non-concrete substructure components. The proper material selection and specification is critical to long-term performance. This is particularly true in harsh environments. Various deterioration mechanisms are discussed in the FHWA Underwater Bridge Inspection Manual. Repair concrete must be specified so that it does not succumb to such deterioration. While state transportation agencies have standard concrete mix designs, these may require modification for underwater repair work. All mix design and materials data should be submitted for review and approval in accordance with the bridge owner’s normal requirements.

4-3.1 Mix Design

Concrete consists of Portland cement, fine and coarse aggregate, water, and mineral and chemical admixtures. Careful selection of these materials yields a durable material that is also easily placed. While the mix design must produce adequate strength, satisfying the mix requirements for a durable and workable concrete for underwater repair will almost always yield a mix with more than sufficient compressive strength to support the imposed loads. Recommended guidelines for concrete mix design are shown in Figure 4-3. All materials used should conform to normal agency specifications. Any materials or tests not covered by agency specifications should satisfy applicable ASTM specifications. Since repairs frequently require placing concrete in small areas or through small pump lines, mixes often utilize maximum aggregate sizes of one-half or three-eighths of an inch. Mix design, particularly as it affects air entrainment, should account for the reduced coarse aggregate size.

Mix Design Guidelines	
<p><u>Fresh Water Placement</u> Minimum Cement Content = 600 pcy 0.40 Maximum Water/Cement. Material Ratio Type I or II Cement Minimum Compressive Strength = 4000 psi Admixtures As Required</p>	<p><u>Salt Water Placement</u> Minimum Cement Content = 600 pcy 0.40 Maximum Water/Cement. Material Ratio Type II or IV Cement Minimum Compressive Strength = 4000 psi Admixtures As Required</p>

Figure 4-3 Minimum Concrete Mix Requirements

Concrete placed in brackish or sea water should utilize Type II or V cement to provide resistance to sulfates found in those waters. Other local waters with sulfates should also use those cements. Ground granulated blast furnace (GGBF) slag cement

conforming to ASTM C989 and GGBF slag cement blended with Portland cement per ASTM C595 are also used in marine concrete.

To maximize concrete durability, the mix should yield concrete with low permeability. Use of a low water/cementitious materials ratio reduces void spaces caused by the loss of free water, thus reducing permeability. Pozzolans react with the free lime liberated during cement hydration and the resulting reaction products act to greatly reduce permeability. Fly ash and silica fume are common pozzolanic admixtures in marine concrete. Mixes typically include 20 to 25 percent fly ash and 5 to 7 percent silica fume replacement of cement.

Various chemical admixtures may be used in the mix. The final mix design is normally determined by the contractor and material supplier based on project specifications along with the chosen placement method, delivery requirements and placement rates. Commonly used admixtures include the following:

- Water reducing and high range water reducers to allow mixes with low water/cementitious ratios to achieve sufficient workability (slump) for placement. Slump of 8 to 10 inches is typical of repair concrete.
- Air entraining admixtures improve the freeze-thaw resistance of concrete and should be used in areas where freezing occurs. Air content is increased when small size coarse aggregate is used in the mix.
- Retarders may be needed to prevent early concrete set when material must be transported long distances, transferred and moved by barge, etc.
- Corrosion inhibitors are available and may be incorporated into the mix. Opinions vary on the effectiveness of inhibitors.
- Pumping aids are admixtures used to facilitate flow of concrete through pump lines.

Anti-washout admixtures (AWA) are chemical admixtures that bind up the free water in the concrete mix and reduce the loss of the fine materials into the water (washout) during underwater placement of concrete. Usage of AWA has mainly developed over the past twenty years. Early AWAs were not compatible with air entraining admixtures, but this is no longer a problem. AWA concrete is very cohesive and can be tacky, and setting times may be longer. High range water reducers are normally used in AWA mixes to improve workability. The U.S. Army Corps of Engineers has developed a test procedure, CRD-C61, to determine the effectiveness of AWA, as well as a material specification, CRD-C661.

Corrosion inhibitors are chemical admixtures that are added in the mixing process. The inhibitors may have adverse effects on some mix properties and their performance must be substantiated by test data. Surface applied corrosion inhibitors are not used below water.

All admixtures should conform to AASHTO or ASTM specifications. Since mixes may contain several admixtures, trial mixes to verify admixture compatibility are recommended. To the extent possible, admixtures should be provided by a single manufacturer.

4-3.2 Reinforcing

Reinforced concrete structures undergoing repair may be reinforced with epoxy coated steel reinforcing bars, uncoated steel reinforcing if they are older, or prestressing strand (primarily in precast piles). Reinforcing may be used in repairs to provide strength, or to improve repair performance by providing crack control and anchorage. Reinforcing used in repairs should be selected to provide durable repairs.

Reinforcing used in repairs should satisfy agency specifications for similar new construction. With a few exceptions, this reinforcing steel will be epoxy coated in accordance with ASTM A775, the so-called “green bar.” Other reinforcing bars are available and may be considered for repair, particularly in more severe environments. Among these reinforcing bar types are the following:

- Epoxy coated bars, ASTM A934, were originally developed for the U.S. Navy for use in marine structures. The bars are coated after fabrication, unlike bars coated in accordance with ASTM A775. The coating is intended to provide increased corrosion protection when compared to epoxy coated bars to ASTM A775.
- Galvanized reinforcing bars, ASTM A767, are available. Corrosion test results for galvanized reinforcing seem to yield varying results. Galvanized reinforcing may experience a slower development of bond strength.
- Alloy steel reinforcing is available in several metallurgies. Alloy steels conforming to ASTM A955-98 (lean duplex steel), A1035 (austenite-martensite) represent reinforcing steels providing improved corrosion resistance when compared to carbon steel reinforcing, with material costs which are less than stainless steel.
- Stainless steel reinforcing is available as solid bars and clad bars. Clad bars consist of a stainless outer layer with a carbon steel core. Clad bars are produced by filling a stainless steel tube with carbon steel pieces, followed by rolling, or by plasma spraying a layer of stainless steel on a carbon steel bar and then rolling it. Type 304 and 316 stainless bars are available and exhibit excellent corrosion resistance. Type 316 stainless is recommended for use in salt water structures. Cut ends of clad bars expose the carbon steel core, subjecting it to corrosion. The cut ends can be covered with stainless weld material as

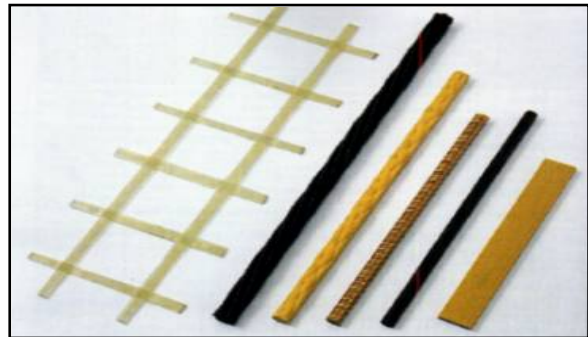

Figure 4-4 FRP Reinforcing Bars

protection. The use of stainless bars in concrete structures with existing carbon steel reinforcing will not increase the corrosion of the carbon steel bars.

- Composite materials composed of fibers in a polymer resin (FRP) are also available for use as concrete reinforcing bars. A variety of material types and bar configurations are produced depending upon the manufacturer, (Figure 4-4). FRP bars do not exhibit yielding prior to failure, and tensile strength may vary with bar size. FRP bars cannot be field bent. No standard ASTM specification covers FRP reinforcing bars. Guidance on their usage and design can be found in ACI Committee Report 440.1.

SECTION 4. MASONRY

Foundations constructed of stone masonry were common for bridges constructed in the 1800s and early 1900s, but have seldom been used over the past several decades. As a result, stone masonry is little addressed in current specifications. Stone is seldom used in repair unless required to maintain visual appearance or the structure is of historic value.

4-4.1 Stone

Stone masonry foundation stonework was predominately of granite, limestone, or sandstone, generally dependant on geographic location. Replacement stone of similar types is available and is supplied as dimension stone in sizes specified by the buyer. Stone specifications should include requirements for compressive strength, modulus of rupture, and durability based on project requirements. ASTM specifications for dimension stone, though written for building stone usage, include C568 for limestone and C615 for granite. Stone should be aged prior to use to allow moisture content to stabilize and stone stress relaxation.

4-4.2 Mortar

Masonry mortars consist of masonry sand, Portland cement, and hydrated lime or lime putty. Mortars with higher cement contents have greater strength and durability, while higher proportions of lime yield a more plastic mortar. Mortar strength is selected based upon structural requirements. Mortars in older structures normally contained higher proportions of lime than modern high cement content mortars. If specifying mortars for repair it is desirable to match the properties of the new mortar with those of the existing mortar.

SECTION 5. TIMBER

Timber used for repair includes replacement piles and sawn timber bracing for bents and bridge protective systems such as shear fences.

4-5.1 Preservatives

Preservative treatments are applied to new timber piles and sawn members to protect them from decay and attack by insects and marine organisms. The use of preservative-treated material may be an environmental concern and should be investigated where treated timber is to be used. Preservatives fall into two primary categories, oil-type and waterborne as listed in Figures 4-5 and 4-6.

Oil-Type Preservatives
Creosote
Pentachlorophenol
Copper Naphthenate

Figure 4-5 Oil-Type Preservatives

Waterborne Preservatives
Chromated Copper Arsenate (CCA)
Acid Copper Chromate (ACC)
Ammoniacal Copper Zinc Arsenate (ACZA)
Chromated Zinc Chloride (CZC)

Figure 4-6 Waterborne Preservatives

Selection of specific treatment chemicals is dependent on the service conditions and timber species. For protection from marine borers, a dual treatment of creosote and chromate copper arsenate is generally used. The American Wood Protection Association (AWPA) standards provide recommended treatments and should be consulted. Guide specifications for pressure treatment include AWPA C1: All Timber Products, Preservative Treatment by Pressure Process and AWPA C3: Preservative Treatment of Piles by Pressure Process. Preservative materials supply and application is highly regulated.

4-5.2 Decay Reinforced Species

The natural resistance to decay and attack of timber varies with the species. Some tropical woods have been marketed as virtually decay resistant, typically resulting from a high resin content and density. Selection of timber should be based on specific performance history, noting that such “natural” resistance can vary within species and even within the same tree.

4-5.3 Fabrication

Timber members should be fully fabricated prior to preservative treatment. Any field cuts or holes should be treated in accordance with the AWPA Standard M4 with a field applied mixture of two percent copper naphthenate mixed with coal tar roofing cement. A state applicators license is normally required to work with these materials.

SECTION 6. COMPOSITES

4-6.1 Components

A variety of polymer products known as composites have been developed for use in civil and structural engineering applications. Composite materials can be created to provide specific properties needed within a given application. Composite materials for structural applications usually consist of polymer resin with fibers (FRP). The resin binds the fibers together, allows load distribution among fibers, and protects the fibers. For structural applications, glass fibers are most common due to their cost advantages, though carbon, aramid, and other fibers are sometimes used. Resins are most commonly polyester or epoxy formulations.

4-6.2 Physical Properties

Physical properties of composites vary between specific applications. Properties can also often be altered to improve the suitability of a product to a specific application. Composite materials are relatively lightweight, which may be an advantage in shipping and installation. Composite materials provide excellent corrosion resistance, a major reason they are used in marine applications. To maximize corrosion resistance the fibers need to be well covered with resin to preclude possible attack of the fibers by water.

Polymeric materials are subject to deterioration from exposure to ultraviolet light. Ultraviolet light promotes cross linking of the polymers that leads to chalking, embrittlement, and degradation of physical properties. The use of dark pigments, colored top coats, and special chemicals in the resins can reduce these effects.

4-6.3 Mechanical Properties

Mechanical properties of composite polymer materials differ in several ways from the steel and concrete most familiar to bridge engineers. Several of the major differences are summarized below.

- FRP members generally have different mechanical properties in each direction (they are non-isotropic) due to the fiber orientation and possibly the manufacturing process. This also means that properties can be tailored by the manufacturer for a given application.
- Materials have high strength to weight ratios due to the fiber strengths.
- The modulus of elasticity of composites is low, which increases deflections. The modulus of the fibers may be high, but the resin modulus is very low.
- Failure strength and other properties are time dependent. The allowable sustained load is smaller than the short term.

- FRP materials are subject to larger creep deformation than steel or concrete. Many designs are controlled by creep limited stresses.
- Properties are temperature dependent. Properties may be reduced at temperatures above approximately 180° F. Conversely, some materials become brittle at cold temperatures.

4-6.4 Example Products

Numerous products are available in a wide range of thermoplastic mixture designs and fiber reinforced designs. Since manufacturers use a wide range of raw materials and processing technologies, every product typically has its own properties and characteristics.

Polymer piles may or may not be fiber reinforced. They are most commonly used as fender piles, but bearing piles are also produced. ASTM D20.20 provides specifications for the various polymer piles. Figure 4-7 shows polymer piles used for a dolphin.



Figure 4-7 Polymer Pile Dolphin

Products intended to be utilized as substitutes for sawn timber are also available. These have been used for walkways, but in larger sizes can be used as fendering along bridge piers and abutments. Figure 4-8 shows a cross section of a square section reinforced with polymer reinforcing rods.



Figure 4-8 Polymer Section with Reinforcing



Figure 4-9 Polymer Sheet Pile Wall

Structured shapes (Figure 4-10) are generally produced by pultrusion; resin-impregnated, tightly packed fibers are pulled through dies shaped to the member in a continuous process. As a result, mechanical properties along the member axis differ from those transverse to the axis. Design information and materials properties are obtained from the manufacturer. Structural shapes can also be built-up, using members or plates. Members are connected by metallic or composite bolts.



Figure 4-10 Platform Built of Fiber Reinforced Plastic Members and Decking

CHAPTER V UNDERWATER REPAIRS

SECTION 1. INTRODUCTION

Most construction activities that are performed above water can be performed below water. Environmental conditions and regulatory constraints at the site will often dictate the most functional and cost effective method to perform the work. Regardless of whether repairs are performed in-the-dry or in-the-wet, the environmental conditions and regulatory constraints during both the implementation and life cycle of the repairs must be closely examined prior to the selection of the repair methodology and material.

SECTION 2. GENERAL CONSTRUCTION OPTIONS

5-2.1 Repairs Performed “In-the-Dry”

“In-the-Dry” refers to construction work performed in a dry worksite. A dry worksite can be obtained by installing cofferdams, constructing dikes, or installing portable dams. Regardless of the method used, creating a barrier between the work area and the water typically allows the contractor to perform and inspect repairs in a dry, manageable environment.

Working in-the-dry is often preferred by contractors due to the increased productivity and work rates. However, the logistics and requirements necessary to produce and maintain a dry site often involve large equipment and temporary works resulting in increased repair costs.

5-2.2 Repairs Performed “In-the-Wet”

“In-the-Wet” refers to construction work performed underwater. Performing repairs below water often involves the use of commercial divers. The support system and equipment used by divers is typically smaller and less costly than that required to produce a dry site. Performing work below water also provides flexibility in the equipment and repair methodology used. Divers can navigate around substructure units below water with ease, provided the environmental conditions do not restrict movement.

Working below water also poses many concerns that the contractor and engineer must be aware of. Site, water, and regulatory conditions all play a significant role in the ability to perform and inspect underwater repair work. Each of these factors can substantially reduce work productivity and increase the repair costs. It is recommended that owners utilize the services of contractors and engineers

experienced in underwater repair that can successfully navigate through these issues and determine a comprehensive repair methodology.

SECTION 3. ENVIRONMENTAL CONSIDERATIONS

5-3.1 Site Conditions

Marine construction activities are more costly than similar activities on land, and this cost may be increased when much of the work is performed by diving. Site access requires boats and crews, along with on-water travel time between the land side staging area and the work site. Depending on the work site location, on-water mobilization may take place miles away.

Marine vessel traffic must also be monitored during repairs. Work times on some waterways may be restricted to accommodate marine vessel movement in the surrounding area. These issues are often addressed during the permitting process and through local marine authorities and the United States Coast Guard.

5-3.2 Water Conditions

Many constraints must be considered when determining how best to perform, schedule, and stage underwater repair work. These include currents, tides, water depth, temperature, and visibility.

Currents are typically observed in rivers as well as tidal currents in coastal areas. Additional currents can result from local occurrences, such as a water discharge through overflow pipes or dam outlet works. Currents and tides can fluctuate daily, affecting the ability of divers to work and the operation of vessels and other equipment. A diver cannot reasonably perform work when currents exceed approximately 2.5 feet per second (fps). When currents exceed 4 fps, it becomes difficult to accurately place and drive sheet piling.

Alternative construction methods can be used to support work in higher currents, including the use of dive shields deployed from an anchored barge or platform (Figure 5-1). The shield will locally block the water flow, creating an area where the diver can work effectively. Costs are typically high and work space restricted when special equipment like a shield is required.

Depth has a substantial affect on work productivity and construction costs. Below

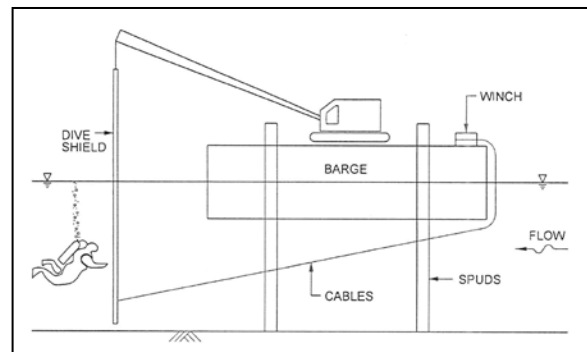

Figure 5-1 Dive Shield Deployed from a Barge

water, the added water pressure acting upon the diver causes physiological changes in the body and in the absorption of gases from the breathing air. These effects increase with depth and limit the time available to safely work at that depth (Figure 5-2). Productivity can vary widely due to current, visibility, temperature, and the strenuousness of the work tasks to be performed.

Bottom Depth	Estimated Productive Bottom Time per Day
3.0m (10 ft.)	6 hours
12.2m (40 ft.)	6 hours
18.2m (60 ft.)	4 hours
24.4m (80 ft.)	3 hours
30.5m (100 ft.)	2 hours

Figure 5-2 Diver Productivity at Various Depths

In addition to diving operations, the cost of dry-condition construction also increases with depth. Greater depths produce larger hydrostatic pressures on the underlying system. To resist these pressures, the amount of material and bracing required to construct cofferdams and dikes will also increase.

Diving operations can be conducted in a wide range of water temperatures utilizing special dive suits that allow the diver's body temperature to remain consistent (Figure 5-3). Work in extreme conditions reduces the efficiency of the divers and their support crews. Dive operations should be scheduled around these conditions, with such work conducted only in emergency situations.



Figure 5-3 Diver Working in Ice

Extreme temperatures may also affect material properties. Cold temperatures can increase cure times or impede the curing process of polymers. Similarly, elevated temperatures may increase the set time of some cementitious repair materials. It is important that material properties and compatibility of repair systems be verified prior to installation and closely monitored during construction.

An underwater visibility greater than 3 feet is desirable in order to properly and efficiently undertake repairs. While divers can perform limited tasks in conditions of poor visibility, minimal below water visibility is required to effectively perform most

construction activities. In some instances, clear water can be brought to the site and pumped into localized areas to increase the visibility; however, this is very costly.

5-3.3 Regulatory

Government and owner regulations can have substantial effects on how repair work is performed, particularly environmental regulations. Construction time may be governed by fish runs and spawning seasons, or birds and land animals in the area. As such, a check of fish and wildlife agency requirements should be conducted during the planning phase. It may also be necessary to demonstrate that no construction materials or processes will degrade the water. Chemical data submissions for concrete and admixtures are often required by various government agencies. Similarly, tests of mortar leakage through forms may be required to show that the cement particles and alkalinity will not affect marine life. Fish survival tests may also be specified by regulatory agencies during construction to evaluate the effects that repair work is having on the marine life (Figure 5-4).



Figure 5-4 Grout Discharge into River

In addition to preventing harmful materials from entering the waterways, it is also important to ensure that existing contamination is not reintroduced to the ecosystem. Of particular importance is the presence of contaminated channel bottom sediments. In areas where bottom sediments are polluted, it may not be possible to excavate or perform operations such as pile driving that may disturb the soil. When excavation and pile driving is permitted, the turbidity can be controlled, but not eliminated, through turbidity or silt curtains. Soil removed from the channel may be classified as hazardous and require the use of approved disposal sites.

Pollution effects on both the diver and the construction must be considered when working in or near the water (Figure 5-5). Water tests should be performed in the repair area on a regular basis to determine the chemical composition of the water and additional precautions that may be required during construction. Divers must take special precautions such as sealed dry suits and helmets to ensure that they are



Figure 5-5 Polluted Waters Mandate That Divers Take Special Precautions

adequately protected from any hazardous chemicals or pollutants that may be in the water. These chemicals may also adversely affect surface preparation and materials placement during construction.

Construction practices can also have an adverse affect on the marine environment. Water column pressure waves created during the pile driving process are becoming an environmental concern, as they are capable of killing fish in the vicinity of the driving operation. One method to reduce this effect is to place air bubble curtains around the pile being driven to inhibit wave transmission. The use of underwater explosives also produces pressure waves, and adequate control measures such as air curtains are usually required.

SECTION 4. METHODS TO OBTAIN DRY WORK CONDITIONS

5-4.1 Traditional Cofferdams

Traditional cofferdams (Figure 5-6) when used in rehabilitation and repair are typically constructed by driving steel sheet piling around an existing foundation to resist soil and water pressures. The area between the cofferdam and the work area is dewatered allowing for work in a dry condition (Figure 5-7).

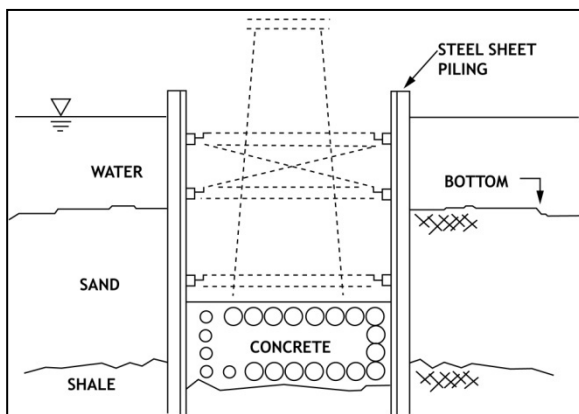

Figure 5-6 Illustration of a Traditional Cofferdam



Figure 5-7 Cofferdam Used for Pier and Foundation Extension

The structural design and detailing of the traditional cofferdam is typically conducted by the contractor's engineer. Special consideration must be taken to ensure the structural integrity of the cofferdam. In addition to resisting hydrostatic pressure, the engineer must take into account the affects of the river current, channel bottom configuration, seepage pressures, water level variation, and site restrictions. Cofferdam design and construction may be further complicated by remains of previous cofferdams and seals left in place and pier batter piles. The contractor determines the maximum water elevation for design, weighing risk factors such as seasonal river changes and work duration. Constructability issues must also be examined by both the

contractor and engineer to ensure that the cofferdam can be erected and dewatered during the course of work. Overhead clearance may limit installation of sheet pile cofferdams around existing bridges. The use of vibratory pile hammers reduces overhead clearance requirements, but room must be sufficient to handle and position the sheets. Sheets can be set in short sections with welded splices, but this is very expensive. Additional concerns arise since the cofferdams are subject to, and may aggravate, local pier scour.



Figure 5-8 Bridge Pier with Dike Constructed of Soil, Traffic Barriers, and an Impervious Membrane

Cofferdams will experience leakage and provisions must be made for continued pumping. This may require personnel to be on site even when construction activity is not underway.

5-4.2 Dikes

Dikes (Figure 5-8) can be constructed around work areas to provide a dry work condition. A variety of materials can be used to construct the dikes, including roadside barriers and plastic sheeting, sand bags, and compacted clay. An advantage of using dikes includes construction with the use of limited heavy equipment and inexpensive materials. However, dikes are restricted to use in shallow water areas with limited flow. In addition, compacted clay and other materials used in dike construction may have to be disposed of as a contaminated material after use.



Figure 5-9 Water Filled Tubular Barrier

5-4.3 Proprietary Barrier Systems

Several types of proprietary barrier systems are available for use on marine projects. Some commonly available systems consist of water filled bladders (Figure 5-9) and membrane covered support frames. These systems are typically limited to waters less than 10 feet in depth having minimal currents and firm river beds with low permeability.

5-4.4 Limpet Cofferdams

Limpet cofferdams (Figure 5-10) are three-sided cofferdams that provide access to pier faces and similar areas. Compressible edge seals are typically used along the cofferdam sides to limit water inflow, with mechanical anchors providing additional support. Water pressure on the face of the cofferdam increases as the inside is pumped out, holding the cofferdam in place. Partial cofferdams, including those constructed of split pipe sections, provide a cost effective means to repair local areas of distress. However, irregular surfaces may require surface preparation and patching prior to cofferdam placement to allow development of the edge seal.

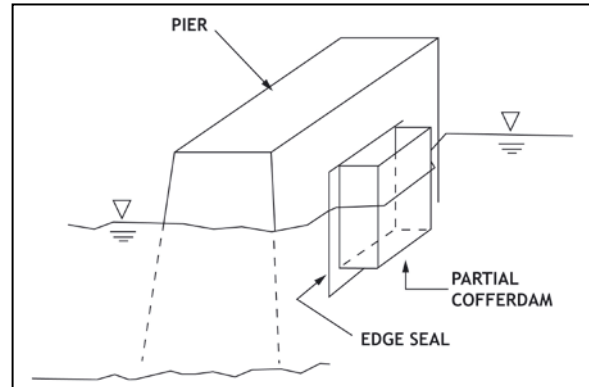

Figure 5-10 Limpet Cofferdam Schematic

CHAPTER VI EQUIPMENT FOR UNDERWATER REPAIR

SECTION 1. INTRODUCTION

A variety of construction equipment is available for use in executing underwater construction and repair projects. Much equipment used for construction on land is also used for marine work. Other specialized equipment is also utilized. An appreciation of the types of equipment available can aid in developing constructible repair designs.

SECTION 2. DIVING SYSTEMS

Primary diving modes utilized by construction workers in conducting underwater repair work are self-contained breathing apparatus (scuba), or surface supplied breathing gas diving. Both may be used; however, most underwater construction work is conducted utilizing surface supplied diving.

6-2.1 Scuba

Scuba consists of a breathing gas supply contained in high pressure cylinders carried by the diver. Scuba provides the diver with good mobility, the equipment is lightweight, and minimal surface support is required. However, the equipment provides a limited breathing gas supply and generally poorer protection from construction activities and poorer communication than surface supplied diving provides. It is more apt to be used for maintenance type activities of limited extent.

6-2.2 Surface Supplied Diving

Surface supplied diving (Figure 6-1) provides breathing gas to the diver by means of a supply line, with breathing gas supplied by compressors or high pressure cylinders located above water. Thus, breathing gas supply is continuous and allows for dives of extended durations. A hard wired communication system provides constant communication between the diver and his topside support crew. Most construction work is undertaken using surface supplied diving methods; however, the choice of diving modes should be left to the contractor.



Figure 6-1 Diver Using Surface Supplied Diving Equipment
(Photo courtesy of Pro-Dive, Inc.)

SECTION 3. REMOTELY OPERATED VEHICLES (ROV)

A variety of remotely operated vehicles (ROVs) have been developed to assist in underwater construction and repair projects (Figure 6-2). While those vehicles can be configured to complete a variety of tasks, they require specialized above water support and are generally quite expensive. The economics of their usage is best determined by contractors as part of their bid preparation.



Figure 6-2 Work Class ROV

SECTION 4. ABOVE WATER SUPPORT

Marine construction requires a variety of above water support equipment (Figure 6-3). Along with standard equipment such as cranes, air compressors, concrete pumps, and similar equipment, barges or floats and boats are normally required. Sectional barges can be assembled (Figure 6-4) in various configurations and used to provide a work platform on inland waters as well as coastal locations.



Figure 6-3 Above Water Equipment on Barge

Diver support located above water includes equipment to provide breathing gas (air compressors, breathing gas storage tanks), diver monitoring and communication equipment, and support for underwater tools or equipment utilized by the divers. Diver support also includes support personnel and back-up divers.

SECTION 5. UNDERWATER TOOLS

Underwater tools include standard hand tools, as well as power tools. Most hand tools, such as pry bars, hammers, wrenches, and scrapers, can be used underwater. In using any tool below water, the diver must have something to hold on



Figure 6-4 Sectional Barges Being Assembled

to or the tool must provide a reactive force that prevents the diver from being moved about in the water as he operates the tool. Figure 6-5 shows divers tightening bolts in a pipe connection utilizing standard ratchet wrenches, holding onto the pipe.



Figure 6-5 Divers Using Hand Wrenches

Underwater power tools are driven pneumatically or by hydraulic fluid pumped through the tools. Any pneumatically powered tool can be used underwater. However, tools specifically manufactured for underwater use are available. These incorporate materials with increased durability. Figures 6-6 and 6-7 show pneumatically powered tools. These tools exhaust the air underwater that drive them, creating bubbles that may interfere with the diver's vision.



Figure 6-6 Pneumatic Needle Gun

Hydraulic tools are powered by hydraulic fluid which is pumped through the tool to drive it, and is then returned to the pump. Biodegradable hydraulic fluids are available and eliminate pollution concerns. Figure 6-8 shows a hydraulic pump and chainsaw. Other tools are shown in Figures 6-9, 6-10, and 6-11. Note that hydraulic tools do not produce air bubbles that can distract the diver's vision. Other power tools available include cut-off saws, chipping hammers, jacks, and impact wrenches. Chipping hammers are extensively used for concrete removal.



Figure 6-7 Pneumatic Drill

Hydraulic tools may also be positioned above water and used for below water tasks. Concrete breakers, excavation buckets, and grapples can be attached to the arm of hydraulic excavators and used by extending the arms below water. Marks placed on the arms can aid in controlling arm positions below water. Hydraulic breakers are efficient for removing large sections of concrete.

Other equipment used for concrete removal includes hydraulic assemblies which are placed into drilled holes and then expanded by hydraulic pressure to split the concrete and wire saws. Expansive chemicals are also placed into drilled holes which, upon chemical reaction, cause pressures that split the concrete around the hole.

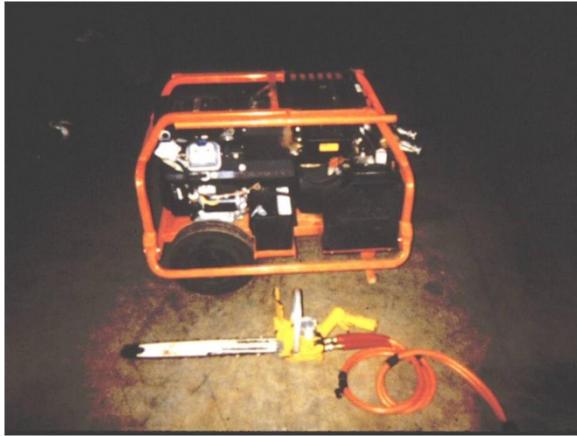

Figure 6-8 Hydraulic Pump and Chain Saw

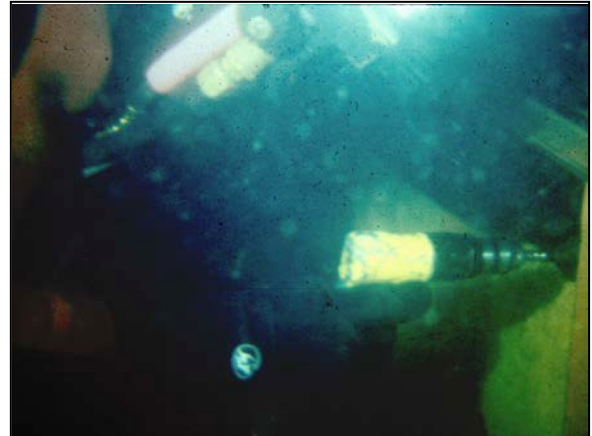

Figure 6-9 Hydraulic Powered Drill



Figure 6-10 Hydraulic Powered Hammer Drill

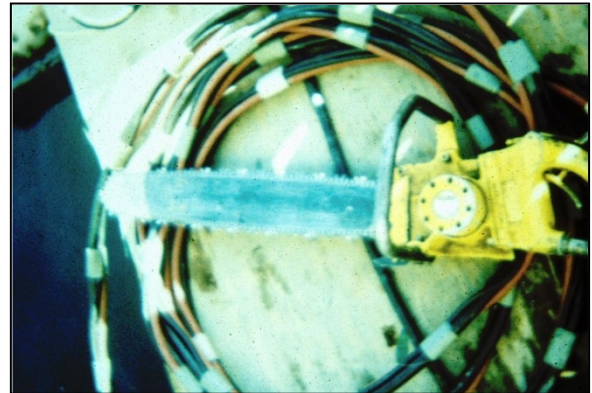

Figure 6-11 Hydraulic Chain Saw

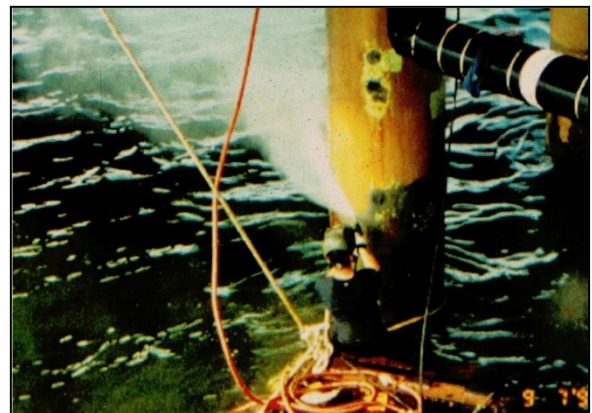

Figure 6-12 High Pressure Water Jet

High-pressure water jets provide an efficient method of removing deteriorated concrete and corrosion and cleaning surfaces to receive repair materials (Figure 6-12). Water is supplied by pumps to a nozzle at pressures exceeding 10,000 psi. Fan jet nozzles are efficient at removing marine growth and fouling. Abrasive materials may be introduced into the water stream for wet sandblasting. This is commonly used for surface preparation where underwater applied coatings are to be used. Ultra-high pressure water jet/abrasive systems using water pressures of 60,000 psi have been used for cutting concrete below water. When used below water, nozzles must provide an equivalent thrust opposite to that of the main nozzle to minimize the force exerted on the diver.

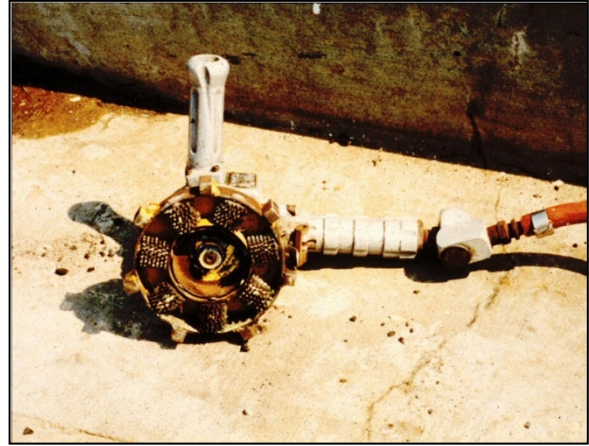

Figure 6-13 Rotary Mechanical Scrubber

Pneumatic or hydraulic powered scrubbers are also available to remove contamination and marine growth (Figure 6-13). These tools work best on flat surfaces. They can be very aggressive, and care must be taken not to remove good material.

SECTION 6. EXCAVATION METHODS

Excavation and removal of debris may be accomplished by various techniques, used either singly or in combination. Common techniques include conventional excavating equipment, airlifting, jetting, and dredging. Factors to be considered in selecting a method for a given situation include type and quantity of material to be removed, water depth, horizontal distance the material must be moved, vertical distance the material must be lifted, water current velocity, and topside support equipment available. Excavation may create turbidity, disturb spawning areas, and cause other potentially adverse environmental conditions. Installation of silt fences, turbidity curtains, or other mitigating measures may be required. This must be evaluated on a site-specific basis. Small, local excavations can be made with hand shovels. In some localities, these small excavations may not require permits, but this must be checked with appropriate agencies at any given location.

6-6.1 Hydraulic Excavators

Hydraulic excavators and cranes with clam shell buckets can be used for excavation and removal of debris below water (Figure 6-14). It may be necessary to position them on a barge to access various areas of a site, resulting in the need for support equipment and crews. Hydraulic excavators can be equipped with pneumatic jaws and breakers for demolition and removal of rock and concrete, or grapples for debris removal.



Figure 6-14 Hydraulic Excavator Performing Underwater Excavation

The working depth of the equipment is limited by excavator arm length and crane cable length. Cameras and acoustic positioning systems have been used to a limited extent to monitor hydraulic excavators. In most cases, though, the operator works by “feel,” along with boom markings and buoys. This equipment is best suited for rough excavation work.

6-6.2 Airlifts

The airlift operates on the principle of differential density. Air is introduced at the lower end of a partly submerged pipe. The resulting air/water mix is less dense than the surrounding water and rises. As it does so, it creates a suction that transports material up with it from the lower end of the pipe. Airlifts consist of a discharge pipe, typically 3 to 12 inches in diameter, an air chamber where the air enters, and an air compressor located above water. Airlifts shorter than 30 feet are inefficient. Airlifts can be used to remove sediment and debris from water depths of up to about 75 feet. Airlifts are diver controlled allowing accurate material removal. They are best at removing mud, sand, silt, clay, and gravel. Excavated material is deposited into barges or simply moved to the side of the excavated area. When deposited relatively close to the point of excavation, some may settle back onto the excavation site.

6-6.3 Jetting

Jetting utilizes the flow of pressurized water pumped from a pump located above water to the jetting tool. The pressure of the water jet on the soil breaks up and displaces the material. Because the water flow from the jetting tool creates a force on the diver operating the jetting nozzle, an oppositely directed reaction force is provided by a balancing jet. Otherwise, the pressure from the water jet would cause the operator to be pushed through the water. Jetting can be used in any water depth. It is good for moving local areas of mud, sand, silt, and clay over short distances. The technique can create poor visibility for the diver and significant turbidity, particularly in higher current areas.

6-6.4 Dredging

Diver-controlled dredging equipment is also available. One type of equipment consists of a flexible suction hose connected to a pump located above water. Another type uses a water jet connected near the intake end of the dredge pipe. As the water jet, aimed at the discharge end, enters the pipe, it creates suction at the intake which carries material off the bottom. Dredging is good for moving soft or loose mud, sand, silt, or clay. It can operate in all water depths, including shallow depths where an airlift is inefficient.

SECTION 7. SPECIAL EQUIPMENT

Marine contractors may develop equipment for particular problems that they encounter and to increase efficiency (Figures 6-15 and 6-16). In developing underwater repair projects, particularly if extensive work is needed, discussions with contractors can be beneficial in learning of such equipment and its potential application. Sources of information in locating contractors and, perhaps, learning of equipment include websites and publications, as well as contractor directories.



Figure 6-15 Specialized Underwater Hydraulic Hammer



Figure 6-16 Contractor Built Pile Cleaning System
(Photo appears courtesy of Substructure, Inc.)

SECTION 8. UNDERWATER WELDING

6-8.1 Introduction

Underwater welding was first accomplished in 1917 during World War I to stop leaks on the seams and rivets in ships' hulls. The first major underwater structural weld was performed in 1971 on an offshore oil rig in the Gulf of Mexico in 130 feet of seawater (fsw). The first dry hyperbaric weld was also performed offshore in the Gulf of Mexico in 1965 on a 6-inch branch line in 80 fsw.

Underwater cutting and the use of oxy-arc burning rods and underwater welding methods has improved greatly in recent years. This section presents some basic information on underwater welding and burning, the role played by oxygen and hydrogen, and some of the factors bridge engineers should be aware of when using these methods for repairs.

6-8.2 Methods

There are several different methods available to perform underwater welding. Most of the procedures are tailored toward heavy offshore and military repairs. For most bridge repairs, where underwater welding might be required, the methods will be less complicated and many commercial diving companies have the resources to successfully accomplish most underwater welding projects. The following list briefly describes various methods currently being utilized:

- Dry welding in a dry habitat at depth pressure out of dive gear—A hyperbaric weld is performed by enclosing the work with a steel structure. The diver enters the structure and displaces (evacuates) the water with air or other suitable breathing gas mixture depending on the depth. The diver then works in-the-dry.
- Dry welding in open bottom cofferdam at depth pressure—Air is pumped into the cofferdam to displace the water in the area to be welded. The diver works in dive gear and is dry above the waist and the welding work is performed in-the-dry.
- Welding inside a closed bottom open top cofferdam at 1 atm—The cofferdam is open at the top and the welder is inside the cofferdam performing the repairs in-the-dry.
- Wet welding at depth pressure—Performing a wet weld without any physical barrier between the welder and the work.

Most bridge repairs would utilize the wet welding method for structural repairs such as welding on anodes, steel pile repairs, or steel sheet pile repairs. As the repairs become more complicated and in deeper water, using a dry habitat would lend itself to a more economical repair. Open top and closed bottom cofferdams are sometimes used on sheet pile and pile repairs.

6-8.3 Welding and Diving Standards and Specifications

Several standards are available to the engineer depending on the type of welds being performed and the type of structures. The following represents a partial list of standards the engineer should be aware of for underwater welding and design:

- Design Standards
 - AWS D3.6 Specification for Underwater Welding
 - API RP2A & API Std 1104 Welding of Pipelines & Related Facilities
 - U.S. Navy Underwater Cutting and Welding Manual
 - U.S. Navy Underwater Ship Husbandry Manual - Cpt. 16 Cofferdams
 - ANSI Z49.1 Safety in Welding and Cutting

- Diving Standards
 - Consensus Standards for Commercial Diving Operations, Association of Diving Contractors
 - 46 CFR 197.200, U.S. Coast Guard Commercial Diving Regulations
 - 29 CFR 1910 Subpart T, OSHA Diving Regulations
 - NAVSHIPS 0994-001-9010, U.S. Navy Diving Manual
 - U.S. Army Corp of Engineers EM-385
 - Association of Diving Contractors (ADC) Consensus Standards

6-8.4 Effects of Wet Welding Versus Dry Welding

There are major differences between welding in-the-dry and welding in-the-wet. The biggest difference is the wet environment surrounding the diver and the weld arc. The heat generated by the weld arc causes the water near the arc to disassociate into its basic components—oxygen and hydrogen. This hydrogen gas is then available for infusion into the weld, leading to possible hydrogen embrittlement.

Other factors affecting wet welds include:

- Infinite Heat Sink—The large amount of water around the weld creates a faster cooling rate which causes loss of ductility and gains in tensile strengths in the steel.

- Depth Pressure—As depth increases, arc instability and resulting weld porosity increase.

- Carbon Equivalent (CE) (*relates chemical composition with hydrogen induced cracking tendencies*)—CE higher than 0.40 can cause hydrogen embrittlement. The CE is more of an issue in wet welds than dry because of the rapid quench rates and availability of hydrogen pick-up.

6-8.5 Weld Design

Underwater welding on bridge structures normally is performed in accordance with AWS D3.6. The AWS D3.6 specification provides for three types of underwater welds: Types A, B, and C.

- Type A welds are structural welds having properties equivalent to welds made in a dry condition.
- Type B welds are intended for limited structural applications and their suitability is based on a “fitness for purpose” as determined by the weld design engineer. The designer should provide the required strength for the completed welds.
- Type C welds are used where structural quality is not critical. They should, however, be crack-free and not detrimental to the structure on which they are placed. They are used where loading is not critical.
- Specific acceptance criteria based on tests of completed welds for each type of weld are contained in AWS D3.6. Most underwater wet welding is specified to Type B or C criteria.
- The following are other factors to be considered in underwater weld design:
 - Use good joint design and keep the joint configuration simple. Make repair doubler plates, gusset plates, and bracing square for ease of fit-up.
 - Design using fillet welds.
 - Ensure the base metal is at least three-sixteenths of an inch thick to avoid burn-through.
 - Visibility—It is important that the visibility for the diver be adequate to perform the work in the wet. Minimum visibility should not be less than 1 to 2 feet.
 - Review material mill certifications or obtain a field sample of the steel piles or sheets prior to specifying underwater welding repairs. The higher strength steels have higher carbon equivalents which require different welding electrodes, particularly for steel sheet piles.
 - When welding in 0 to 10 feet of water, the arc is more unstable than in deeper water and more turbulence in the gas bubble is created because of an air lift effect.
 - Vertical welds should always be executed down. Attempting to push the weld puddle uphill leads to porosity.

- Avoid overhand welding which is most difficult and creates more porosity. The gas bubble stays longer so the molten bubbles (porosity) have more time to reach the surface rather than solidify.
- Welds should be designed and specified for each specific application. Some commonly used weld types for various applications are:
- Attaching anodes to steel members—Class C weld, use E6013 or E7014 electrodes
- Sheet pile patch plates—Class C weld (if acting as form), use E6013 or E7014 electrodes or E309 stainless steel or nickel (expensive) electrodes depending on CE
- Doubler plates for section loss to sheet pile pipe or HP piles—Class B weld, use E6013 or E7014 electrodes
- Bracing connections—Class B weld, use E6013 or E7014 electrodes

Wet welds are commonly made using the shielded manual arc welding (SMAW) technique. Use of flux cored arc welding (FCAW) produces higher porosity and a more unstable weld profile.

6-8.6 Weld Qualification

For underwater welds, both the welder and weld procedure must be qualified for the welds to be performed. There are no prequalified underwater welds. All welders working underwater should be qualified welders per AWS standards for above water welding.

In qualifying an underwater weld, a test assembly that matches the production welds is prepared, taken below water to a depth similar to the production welds, and welded using the materials, procedures, and technique specified in the written weld procedure. The sample is then brought above water and subjected to testing as prescribed by AWS D3.6 for the specific type of weld. If the sample is satisfactory, production welding may begin.

A Weld Procedure Specification (WPS) should be required for all underwater welding, and submitted for review per standard agency procedures. The following should be included (as a minimum).

- Introduction
- References
- Weld procedure parameters

- Weld process
 - Filler metal
 - Welding position and direction
 - Welding technique and number of passes
 - Time lapse between passes
 - Electrical characteristics
 - Travel speed
 - Depth of welding
- Electrode handling procedure
 - Inspection procedure and requirements
 - Repairs to any defective welds
 - Welder qualification
 - General requirements
 - The CE of metal for wet weld

6-8.7 Underwater Burning

Essentially the same equipment used for underwater welding is also used for burning. Although both wet welding and burning produce gases that should be vented, the underwater burning poses more danger. Since most manufacturers' rods use oxygen in the burning process, there is an increased risk for explosion. However, it should be noted that regardless of whether oxygen is used, there is still the risk for an explosion with hydrogen build-up that may combine with gases other than oxygen to cause an explosion. Underwater burning should only be conducted by experienced personnel.

Burning might be specified to cut out damaged sheet piles or steel bridge piles to initiate underwater welding repairs. There are several different types of underwater burning methods. However, only the conventional method of using oxy-arc or exothermic rods will be presented here.

Some of the issues associated with underwater burning are:

- Explosions—As underwater burning takes place, hydrogen is created at the tip of the electrode from the burning process of the metal. If the hydrogen is not vented properly it becomes a highly explosive gas as it builds up in the contained member which can cause a deadly explosion. This normally occurs when the hydrogen gas begins to occupy approximately 7 to 15 percent of the volume of the member in which it is contained. When oxygen is added to the mixture (from the cutting) it can become very explosive if not vented properly.

- If a burning operation is being conducted, then mechanical venting by cutting a vent hole on the members should be performed to vent gas build up prior to any burning operation. The engineer should require a burning and welding operations plan that details venting procedures prior to field work.
- Direct Current Electrode Negative DCEN (straight polarity)—Regardless of the type of underwater burning being conducted, under no circumstances should an alternating current (AC) power source be used.

CHAPTER VII PIER REPAIRS

SECTION 1. INTRODUCTION

Bridge piers are predominately constructed of reinforced concrete, and repair techniques utilized for underwater repairs are similar to those used above water. Common types of deterioration requiring repair includes material degradation, impact damage, and undermining of foundations. Deterioration mechanisms are covered in the Underwater Bridge Inspection Reference Manual. Much of the information presented in this chapter on formwork, concrete placement, and polymer injection is applicable to all concrete structures. Concrete walls, box culverts, any MSE wall panels in water, and other surfaces can be repaired by application of the techniques presented in this chapter.

SECTION 2. FORMING SYSTEMS

A variety of forming systems are used for underwater placement. Form pressures below water are reduced due to the water pressures countering the concrete pressures. Tremie placement, formed and pumped concrete, and preplaced aggregate concrete placement methods are common below water, and can create pressures exceeding standard placement methods. Forms should be carefully fitted to preclude leakage of material into the water. Forms are generally preassembled above water in the largest practical sections to minimize work by divers. Where currents are present, all form openings must be well sealed to eliminate washout of concrete. Formwork can be grouped into two broad categories: rigid and flexible.

7-2.1 Rigid Formwork

Rigid forms have internal stiffness and maintain their shape during placement. The various commercial formwork systems used in standard concrete bridge construction as well as custom built forms of wood, precast concrete, or metal represent common rigid form systems. These systems can be readily utilized underwater (Figure 7-1). Advantages of rigid forms include their familiarity, potential for multiple uses, and ability to provide clean and neat repair surfaces.

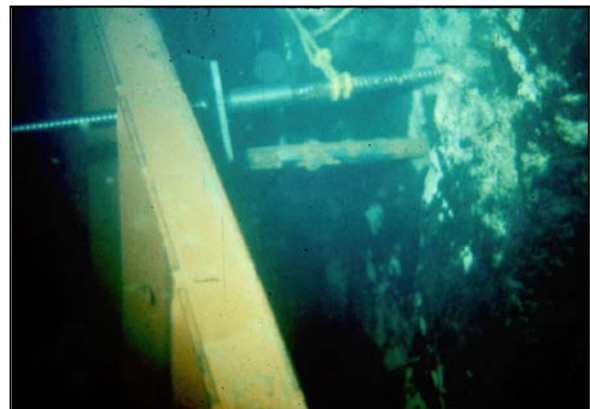

Figure 7-1 Commercial Rigid Form for Pier Repair Underwater

Due to the cost of removal, contractors may elect to leave formwork in place unless not permitted by project specifications. Where forms can be left in place, the owner's inspectors should assure that the forms are in good condition, and not something a contractor simply wants to be rid of. When forms are left in place, they may provide a barrier that reduces the exposure of the concrete to oxygen and chlorides, or provide abrasion resistance. If intended to provide such benefits, the long-term durability of the forms and possible dislodgement should be evaluated. Form release agents used on underwater forms must not contaminate the water.

7-2.2 Flexible Formwork

Flexible forms may be composed of fabric or thin polymer sheets. Flexible forms lack internal stiffness and assume a shape resulting from the pressure of the contained concrete or grout. Flexible forms are most often found utilized as forms for pile jackets or as bags which are filled with grout for undermining repair or as riprap replacement. Their use as pile jackets is discussed in Chapter VIII. When used to form flat surfaces such as a pier face, fabric forms are stiffened using a steel grid. Grids of reinforcing rods, welded wire fabric, or light metal sections have been used. Flexible forming systems normally remain in place, though some flexible polymer forms are sometimes removed.

Advantages of flexible forms are low cost, light weight, and ease of transporting, and their ability to conform to gaps or voids into which they may be placed when filled with concrete or grout. They can be difficult to handle and set in currents. Fabric forms are deformed by the concrete during placing and may yield an irregular surface. Flexible forms are composed of polymer materials that degrade in sunlight. This may result in an unattractive appearance. The potential for mix water bleeding through the fabric carrying cement fines may be an environmental concern. Fabrics are, however, available with a weave fine enough that only water can pass through.

Fabric used for flexible forms typically has a tensile strength ranging from 200 to 400 pounds per linear inch. The form material may stretch as much as 10 percent under loads of 50 percent of the fabric tensile strength. Thus, allowance in computing concrete or grout volumes must consider stretch.

7-2.3 Concrete Preparation

Prior to setting formwork, all loose and deteriorated concrete, or other materials where concrete is used to repair a non-concrete substrate, must be removed as discussed in Chapter V. Repair edges should be saw cut or chipped to provide a vertical or slightly undercut edge around the repair. Where the forms are not open at the top, the repair area should be profiled, or the forms provided with vent pipes, so that high or "domed" areas are not present that can trap water and lead to voids or weakened concrete as the concrete rises in the forms.

SECTION 3. REINFORCING

Concrete repairs usually include reinforcing steel to restore steel area lost to corrosion, provide increased strength, or to control cracking and improve anchorage of the repair to the substrate. Epoxy coated reinforcing steel or welded wire fabric is most often used, though other materials (see Chapter IV) are sometimes used.

7-3.1 Design Considerations

Concrete repairs often are the result of corrosion induced deterioration. Where corrosion has significantly reduced the cross sectional area of reinforcing steel available to resist imposed loads, new reinforcing should be added to restore the lost area.

New steel provided to restore area lost to corrosion or to provide increased capacity must be detailed for the required splice or development length. Installation of this steel requires removal of sound concrete in the splice or anchorage areas, a costly procedure underwater. Use of small reinforcing bars with resulting reduced splice and development lengths can reduce the extent of concrete removal. Mechanical splices can also be used underwater; welding is not recommended.

To improve long-term repair performance, reinforcing steel should be included in the repair area. Hooked dowel bars, often No. 3 bars spaced at 18- to 24-inch centers, can be drilled and grouted into the substrate concrete to improve anchorage of the repair concrete. Welded wire fabric, an 18-inch grid of No. 3 reinforcing bars, or similar steel, should be included in the repair to reduce cracking in the repair.

7-3.2 Surface Preparation

Reinforcing steel should have corrosion products removed before installing new reinforcing or repair materials. Underwater cleaning of steel is accomplished using high pressure water or abrasive cleaning. Small projects may use power wire brushing. Steel must be cleaned over its entire area. Concrete removal should extend behind the reinforcing steel for a minimum of approximately one inch.

7-3.3 Anchorage

Concrete repairs often utilize one sided forms anchored to the concrete structure being repaired. Forms can be anchored using mechanical or grouted anchors, (Figure 7-2). Drilled and grouted reinforcing bars are used to anchor repair



Figure 7-2 Permanent Steel Plate Form Secured with Expansion Anchor

or new concrete into existing concrete. Anchor systems used underwater are installed in a manner similar to those used above water. When choosing expansion anchors for installation by divers it should be expected that the drilling of precise holes will be difficult due to currents and the need for the diver not only to position the drill but to also provide a reaction point to resist the drill torque and impact. Anchors that are more tolerant of variations in hole size are recommended.

Grouted anchors are set using cement grouts or polymer grouts, most often epoxies. Polymer materials must be formulated for use underwater. The use of capsule style adhesives is discouraged. Capsules do not fully fill the drill hole, leaving a layer of water that becomes intermixed with the adhesive when the anchor bar is inserted and spun. Recommended installation procedure for grouted anchors is to drill the required size hole, clean the hole inside by brushing, fill the hole with adhesive, and then place the anchor bar into the grout filled hole. USACE tests have shown that polyester anchorage resins may creep when installed underwater.

SECTION 4. CONCRETE PLACEMENT METHODS

Concrete placement methods used for underwater concrete need to minimize washout of fine material from the concrete or grout and any intermixing with water that may be present in the forms. Water flow across the surface of freshly placed concrete should be prevented.

7-4.1 Hand Patching

Hand applied patches are used for shallow repairs of limited area, often as a maintenance activity. Patch material may consist of a Portland cement mortar, hydraulic cement mortar, epoxy mortar, or, for very shallow repairs, neat epoxy. Hydraulic cement and epoxy mortars are primarily used, and pre-packed proprietary repair products are readily available.

The area to be repaired is first cleaned of loose or deteriorated concrete and all marine growth or other contaminants.

The materials are mixed above water. They are then taken below water in closed containers and applied to the repair area using a gloved hand or trowel. Mixing and application of proprietary products must follow manufacturer's requirements. The bond of properly mixed and placed materials is very good.

7-4.2 Tremie Placement

Tremie placement is a well developed method for placing underwater concrete in new construction as well as for repairs. Work by the USACE has demonstrated the ability to place thin concrete placements utilizing tremie techniques in conjunction with concrete mixtures that include silica fume, fly ash, and AWA.

Tremie placement typically utilizes a vertical metal pipe with a hopper on top through which concrete is directed to its point of placement underwater. The initial concrete is separated from the water by a pig inserted in the tremie pipe ahead of the concrete, or by having the pipe closed at the mouth by a valve. After filling the pipe with concrete, the pipe is raised to allow the pig to escape or the valve is opened. Initially, tremie pipes should not be raised more than 1 to 2 feet to establish flow. Concrete continues to be placed through the pipe, keeping its mouth embedded in the seal created by the previously deposited concrete. The tremie must not be raised above the top of the concrete being placed. The concrete gradually expands the initial seal to fill the placement.

Tremie pipes must allow rapid concrete placement. Pipes from 8 to 12 inches in diameter are usually used for large placements. Smaller pipes can be used for repairs with small aggregate concrete. Pipe joints should be well sealed so water is not sucked into the pipes and damage the mix. Pipe spacing of one tremie pipe per 300 square foot of placement surface area has been a rule-of-thumb for large placements. Pipe spacing for repair placement is based on the contractor's experience with the tremie pipe and mix used on the project.

The maximum aggregate size for tremie mixes for reinforced concrete members is typically three-fourths of an inch; smaller maximum sizes may be used for repairs. Fine aggregates normally make up 45 to 55 percent of the total aggregates, in a cement rich mix. Water reducers and anti-washout admixtures are normally used, with a minimum slump of 8 to 10 inches. For concrete to self-consolidate underwater under its buoyant weight, slumps of at least 7 inches are required. Test mixes are advised.

Sufficient concrete must be available to assure continuous placement. Tremie concrete differs from pumped concrete in that the concrete flows away from the tremie pipe by gravity as opposed to pump pressure. Tremie pipes inclined from the vertical by up to 45 degrees have yielded good results for thin placements due to the tendency of the concrete to flow away from the pipe. During placement, the rate of placement, the quantity placed, and the elevation and spread of the placed concrete should be continuously measured. This data can then be compared to the expected placement configuration as a means of detecting any placement problems.

Where possible, concrete should be "over placed" such that the first concrete placed that has been affected by contact with the water is removed through vent or overflow pipes, or is subsequently removed after placement by chipping and water cleaning. Otherwise a top layer of laitance and weaker concrete remains. This also applies to placement by pumping.

7-4.3 Pump Placement

Pumped concrete and grout depends on the pressure of the pump as well as gravity to reach its final location. Pumping of concrete and cement grout is the most common

method of placement for underwater repair. Mixes designed for pump placement are similar to tremie mixes, with aggregate size adjusted to suit the pump line size. The maximum size of coarse aggregate should not exceed one-third of the pump line diameter. Incorporation of anti-washout admixtures can yield mixes capable of two to three feet of free discharge from the end of the pump line with minimal washout of fine material. The concrete mix should be proportioned to assure flow after leaving the pump line.

Pump lines to be handled by divers are normally smaller than those used for above water placement. The use of a pump line facilitates relocating the placement point when the repairs consist of several smaller placements. For initial placement, a pig is used to limit mixing of concrete and water in the line. Once placement starts, concrete flow should be continuous till the placement is complete. The discharge end of the hose should be kept immersed in the concrete when possible. An air vent near the highest point of the pump line is used to prevent a vacuum blockage developing in the line due to flow separation in vertical line segments. As with tremie pipes, all pump line connections must be tight so water is not pulled into the concrete.

Quality assurance sampling and testing of the concrete or grout mix is performed above water on the delivered mix prior to placement. Collection of samples at the point of placement underwater is impractical due to intermixing with water that would occur in trying to secure a sample.

7-4.4 Preplaced Aggregate Concrete

Preplaced aggregate concrete (PPA) is a two-step process in which aggregate is first placed into the forms and a cement grout is then pumped into the aggregate producing in-place concrete. Preplaced aggregate concrete has been used for many years and is well suited to underwater construction. Preplaced aggregate concrete can be used for most repair applications where the repair thickness is greater than two inches. Point-to-point aggregate contact and good aggregate distribution are maximized since the aggregate is hand placed. This reduces concrete shrinkage and subsequent cracking of the repair.

Guidance on mix proportioning for preplaced aggregate concrete is contained in ACI Committee Report 304.1R. Preplaced aggregate concrete differs from conventionally placed concrete in that it has a higher percentage of coarse aggregate. Since the coarse aggregate is hand placed, its size is not controlled by the diameter of pump lines or tremie pipes. Grouts used for PPA concrete are most often prepackaged materials formulated specifically for PPA concrete use. Grouts must be easily placed and have minimal bleeding. Grout flow is measured using the flow cone method, ASTM C939. Flow of 20 to 24 (± 2) seconds is generally specified for underwater placement, but should conform to manufacturer's requirements when prepackaged materials are used.

Formwork must fit tightly to contain the fluid grout and be substantial enough to withstand grout injection pressures. Edges against existing concrete can be sealed with mortar, caulking rope, or compressible materials. Grout inlets and vent ports are provided in the formwork, typically made of 1 ½-inch to 2-inch PVC pipe. Each inlet or port is equipped with a valve. When practical, a vent pipe should be provided which extends above water.

After the repair area is properly prepared and any reinforcing steel placed, forms are set and the void area filled with coarse aggregate. Forms for larger repairs are set vertically in sections to facilitate aggregate placement. Formwork for smaller repairs can be provided with temporary openings, “windows,” for aggregate placement. After the aggregate is placed and the formwork sealed, grout placement is started by pumping through the bottom port, and progressing upward as needed (Figure 7-3). Grout preparation and pumping is performed above water and supplied to the divers through a pump line. Pump pressures are typically 10 psi above the static water head at the repair.

7-4.5 Bottom Dump

Placement of concrete underwater by bottom dump or free dump is sometimes used to fill eroded areas or for casting concrete slabs. Covered skips or bottom dumping buckets are used to deliver concrete to the point of underwater placement, where the bottom is opened and the concrete allowed to free fall to its final location. Concrete for bottom dump placement should be proportioned to be cohesive and should contain anti-washout admixtures. Free fall during placement should be limited to approximately 1 foot. The application of bottom dump placement for bridge substructure repair is limited,

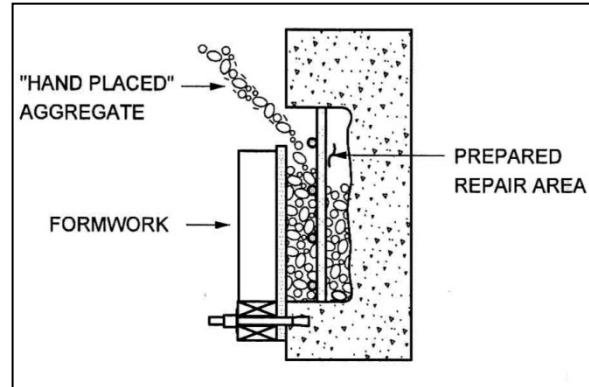

Step 1: Form and Aggregate Placement

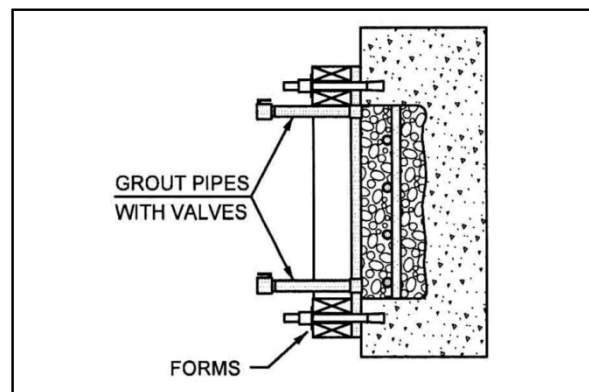

Step 2: Finished Forms and Aggregate Placement

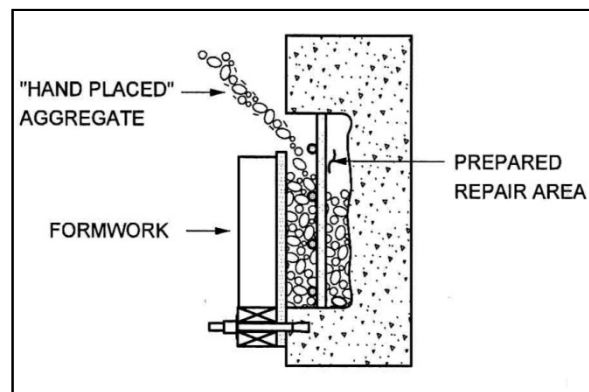

Step 3: Grout Pumped through Aggregate

Figure 7-3 Preplaced Aggregate Concrete Placing Sequence

but may be practical in filling scour holes or placing thick channel linings. The method should not be used when significant currents are present.

7-4.6 Bagged Concrete

Bags filled with concrete or grout can be used to fill void areas (Figure 7-4). Fabric bags are filled above water and placed by divers. For underwater use, bags are sometimes filled with a dry concrete mixture allowing the surrounding water to provide hydration after placing. This is not recommended as the interior may not fully harden.

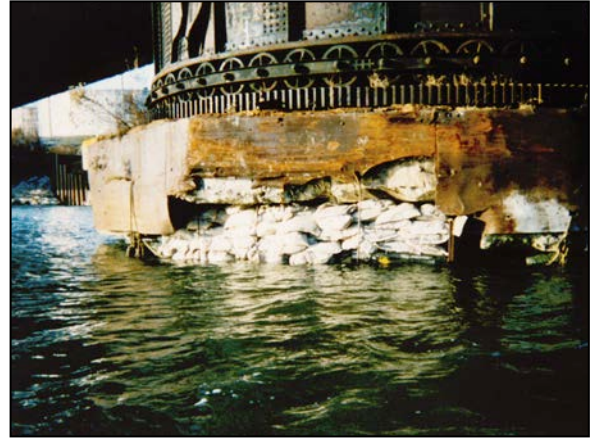

Figure 7-4 Bagged Concrete Emergency Repairs to Swing Pier

Bagged concrete can be used to help secure the bottom of forms placed on the stream or sea bed and to provide bank erosion protection. Use of larger bags filled in place with grout or concrete is described in Section 7.

SECTION 5. CRACK REPAIR

7-5.1 Routing and Sealing

Routing and sealing of cracks can be used where a structural repair is not needed. The crack is enlarged and filled with a flexible sealant, normally in an effort to reduce the ingress of water (chlorides). This technique is seldom applied to underwater structures due to the cost of diving labor to prepare the crack and the need for a sealant that can readily bond to the saturated concrete.

7-5.2 Epoxy Injection

Repair of cracks in splash zone and underwater concrete by injection of epoxy resins has been successfully undertaken since the 1960s. Epoxy crack injection is used to restore the structural integrity of the concrete by bonding the crack surfaces together or filling small void or honeycomb areas. Physical properties of concrete repaired with epoxy injection are similar to the original concrete, but do not provide any increased strength. Only non-moving cracks should be repaired by epoxy injection. A low viscosity resin may penetrate cracks as narrow as 0.015 inches.

Epoxies for resin injection are 100 percent solid, 100 percent reactive epoxies with low curing shrinkage. Materials should conform to the requirements of ASTM C881 and have test data supporting their ability to cure underwater and bond to water filled

saturated cracks in fresh or salt water. Epoxy materials for the seal coat and injection resin must be capable of being placed and curing in water temperatures experienced at the repair location. Cold water increases resin viscosity and slows, or can even halt, resin curing. When injecting resins underwater, the resin mixing and pumping equipment is placed and operated above water (Figure 7-5). This can result in long hoses running to the injection point and cause concerns when resin viscosity is high.

Execution of injection repairs underwater is similar to above water use. Cleaning of the crack area by mechanical methods such as hydraulic operated needle scalars or by high pressure water is necessary to remove contaminants and allow bond of the seal coat. Underwater cracks may contain dissolved mineral salts, silt and clay, and corrosion products, as well as water. These materials will reduce bond and may not be able to be completely removed. Flushing of cracks with fresh water injected through the ports after installing the seal may partially clean the crack surfaces. The surface seal may be an epoxy or a hydraulic cement material. Selection should be by the contractor based on water temperature, currents, set time, and experience (Figure 7-6). Installation method and spacing of injection ports will vary with resin supplier's requirements. The epoxy is injected starting at the lowest injection port. Resin is injected at that port until clean resin exits the next higher point, at which time the lower port is sealed and injection starts at the next higher port (Figure 7-7). This process continues until the whole crack is filled. Injection pressures of 20 to 150 psi over ambient water pressure are commonly used. Seal



Figure 7-5 Epoxy Injection Equipment on Float

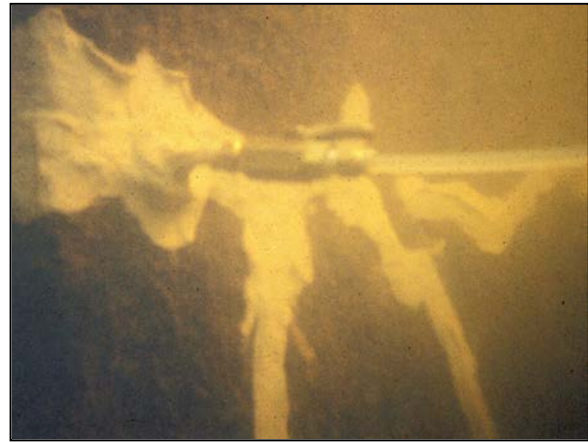

Figure 7-6 Injection Ports and Seal Coat

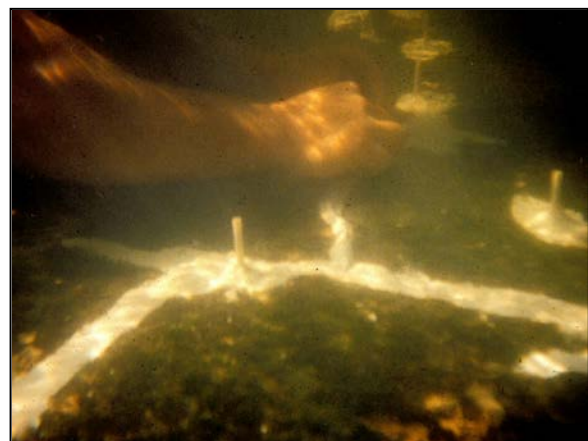

Figure 7-7 Injection of Resin through Port

coats and injection ports are left in place, unless they are visually unacceptable where a repair extends above water.

Quality assurance should include materials data submittals and review of detailed installation procedures. Injection pressures should be monitored for any abrupt or significant changes and the completed work inspected for signs of seal rupture or resin leakage. In critical installations cores of injected cracks can be obtained to verify epoxy bond and penetration. Ultrasonic pulse velocity testing has also been used to check crack penetration, but may be questionable underwater due to the potential water in any unfilled cracks.

SECTION 6. MASONRY REPAIR

Repairs to masonry piers include stone replacement with new stone, replacing stones with cast-in-place concrete, and repointing of mortar joints.

Replacing deteriorated stone with new stone of the same type maintains appearance of the substructure. While always desirable, visual consistency may be mandatory for historic bridges. Stone replacement starts with removal of the old stone, taking care not to damage adjacent stonework. All old mortar is cleaned from the surfaces of the stone cavity, and the new stone is placed using shims to provide mortar joint space. The mortar joint is then filled with mortar. New mortar should match the existing mortar in composition and color.

When appearance is not important, the area left by removal of a deteriorated stone can be formed and filled with concrete or grout. Form liners can be used to match adjacent stone appearance. Concrete or grout is pumped into the form through ports in the forms.

Extensive stone deterioration around the waterline can be repaired by constructing a concrete encasement around the pier (Figure 7-8). The encasement should be reinforced to preclude cracking and must be of durable concrete. The top should be sloped so water drains away from the pier shaft.

Repointing of masonry joints is performed where loss of mortar has occurred. Older mortars containing high proportions of lime may be particularly susceptible to loss as water running by the joints leaches out the lime in the mortar. Mortars containing a higher proportion of Portland cement provide improved resistance to erosion, but



Figure 7-8 Concrete Encasement of Stone Pier

their added hardness may cause local spalls when combined in joints of softer mortars. Repointing involves removal of loose mortar using a joint rake or high pressure water and applying new mortar well compacted into the joint. Repointing mortar usually consists of hydraulic cement and sand, mixed above water and carried underwater in plastic bags for placement. Large repointing projects may use grout pumped through a metal nozzle to pressure grout the prepared joints.

SECTION 7. UNDERMINING AND LOCAL SCOUR REPAIRS

Numerous techniques are used to repair foundation undermining and areas of local pier or abutment scour. Several of the more commonly used techniques are discussed in this section. Repairs are undertaken in response to observed conditions. These conditions may not represent the most severe effects that could occur. Prior to executing repairs a scour study addressing hydraulic behavior and geotechnical parameters as well as structural performance should be completed.

References for scour and scour countermeasure analysis include the following:

- Hydraulic Engineering Circular No. 18, "Evaluating Scour at Bridges"
- Hydraulic Engineering Circular No. 20, "Stream Stability at Highway Structures"
- Hydraulic Engineering Circular No. 23, "Bridge Scour and Stream Instability Countermeasures, Experience, Selection, and Design Guidance"
- National Cooperation Highway Research Program Report 568, "Riprap Design Criteria, Recommended Specifications, and Quality Control"

7-7.1 Undermining Repairs

Repair of abutment or pier undermining is intended to replace the scoured material below the foundation with non-erodible material. One approach is to dewater the area by use of a cofferdam and form and place concrete to fill the undermined area. Measures that can be taken without the use of a cofferdam include grout bags, concrete fill, and grouted stone.

When replacing eroded material below spread foundations with concrete or grout it is generally assumed that the new material is at least as strong as the lost material, and hence adequate bearing is restored. Actual load distribution may not be consistent with this due to added stiffness of the new material or redistribution of pressures that took place due to the undermining. Such aspects should be carefully considered as part of the repair design. Where piles are exposed in the undermined area, the piles can be wrapped with polyethylene sheeting, or similar material, to act as a bond

breaker to reduce added vertical dead load transfer to the piles resulting from the concrete fill.

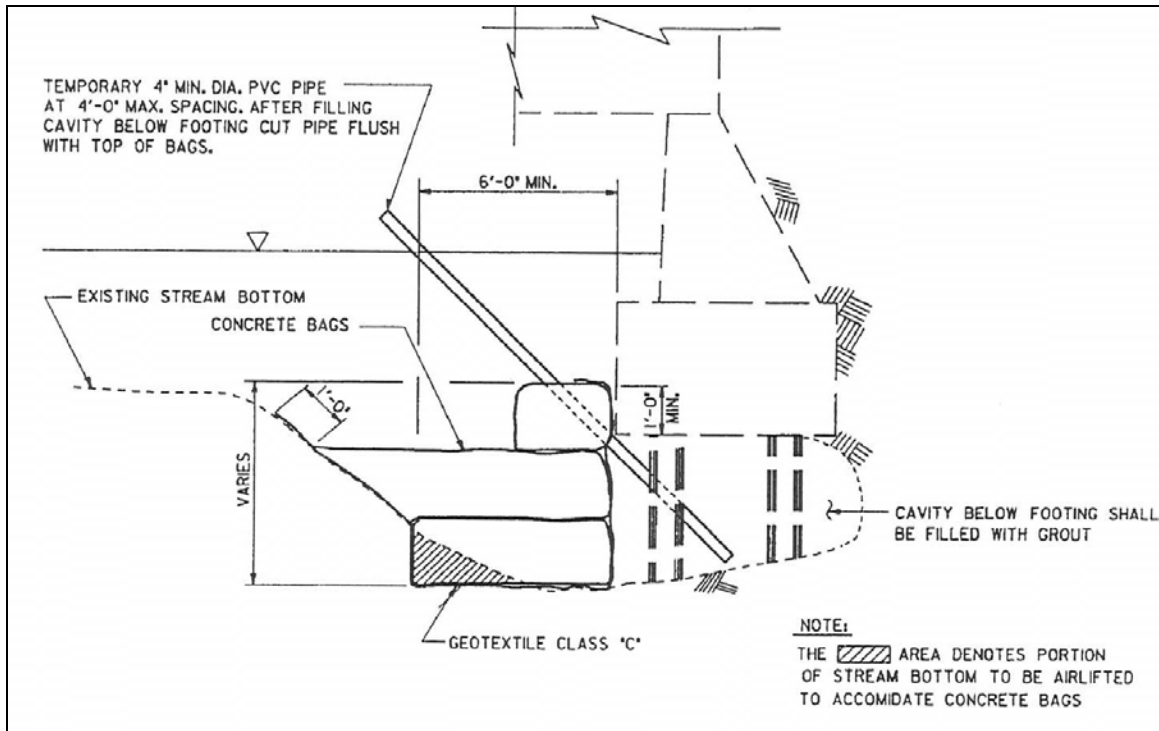

Figure 7-9 Grout Bag Repair at Abutment

7-7.1.1 Grout Bags

Grout bags along with concrete or grout fill are often used for repair of undermining due to their ease of placement, ability to conform to irregular spaces and channel bottom profiles, and relatively low cost. A schematic for a typical grout bag repair to an abutment is shown in Figure 7-9. Experience has shown that grout bags ranging in size from 4 to 8 feet long, 3 to 4 feet wide, and 1 foot thick work well. Minimum fabric strength should be 400 pounds per linear inch tensile strength. The leakage of cement fines and alkaline waters from the fabric should be assessed for environmental effects. Installation of grout bags generally follows the following procedure:

- 1) Remove sediments and debris from the undermined area.
- 2) Install debonding membrane on piles as desired.
- 3) Set grout bags.
- 4) Set grout pipes and vent pipes into the undermined area. Four inch PVC pipe or similar is generally used.

- 5) Fill bags with grout. Where bags are stacked, reinforcing bar dowels can be pushed down through the bags to resist any tendency to roll.
- 6) After the grout in the bags has set, fill the undermined area by pumping in grout or concrete, through the grout pipes. Material should be pumped until clean grout or concrete is observed coming out of the vent pipes.
- 7) Remove grout pipes if desired.



Figure 7-10 Grout Bag and Inlet Pipe

A typical grout mix includes 850 pounds per cubic yard of cement (Type II if in sea water), fine aggregate, a water cement ratio of 0.80, air entrainment, and anti-washout admixture. A minimum specified compressive strength of 3500 psi is commonly used. Grout may contain 3/8-inch coarse aggregate. Figure 7-10 shows grout bags in place waiting to pump grout into the inlet pipe.

Undermined areas can also be filled with concrete placed inside rigid forms. Figure 7-11 shows a steel form with the bottom edge trimmed to fit the streambed profile at the pier in the background. The form was secured to the edge of the footing and the void area pumped full of concrete through inlet pipes in the plate. Driven sheet piling can be used as formwork, and has the ability to also provide long term scour protection if driven to adequate depth. The sheet piles may be driven 1 or 2 feet outside the footing to provide space for tremie placement of concrete. Sheet piling, or any other permanent formwork, should not extend above the top of the footing or pile cap.



Figure 7-11 Steel Plate Form Trimmed to Fit Stream Bed

Grouted stone is another technique used in filling undermining and adjacent scour holes. Grouted stone is similar to a very large aggregate PPA placement. Relatively large stone is placed in the undermined and scoured area along with grout fill pipes at the bottom of stone placement, and vent pipes at the top. Grout is then pumped into the stone, solidifying the mass. An example stone gradation is shown in Figure 7-12. The corresponding grout mix was one part cement to two parts sand, a water cement ratio of 0.70, and admixtures. A pump pressure of 5 psi over water pressure has been

used successfully. Grout placement must be controlled and should be monitored by divers to assure it does not begin flowing into the river.

7-7.2 Scour Countermeasures

$$D_{50} = 1'$$

$$1.26 D_{50} \leq D_{100}$$

$$D_{100} \leq 1.71 D_{50}$$

$$D_{15} = 0.5 D_{50}$$

Gradation tolerance, $\pm 10\%$

Hydraulic Engineering Circular (HEC) No. 23 provides design methodology for various scour countermeasures. Scour countermeasures addressed in this section are limited to some common techniques used for local pier or abutment scour.

Figure 7-12 Stone Gradation

7-7.2.1 Riprap

Stone riprap is perhaps the most prevalent technique used for local scour protection. However, HEC 23 advises that riprap utilized as scour protection must be inspected after each high flow event to assure it is stable. Equations for sizing riprap for various applications are found in HEC 23.

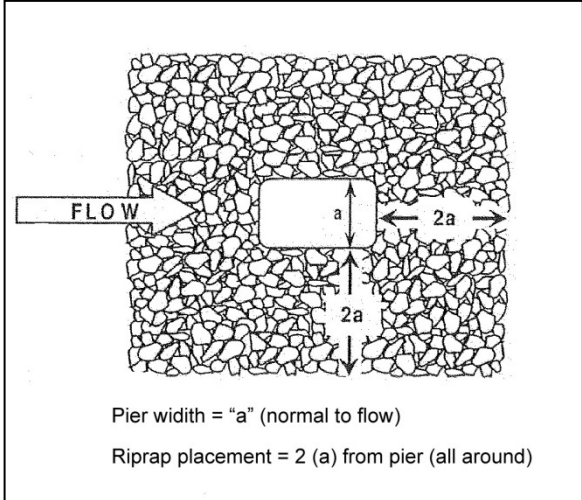

Figure 7-13 Plan View of Riprap

For riprap to perform as designed it must be of proper size and configuration and properly installed (Figures 7-13 and 7-14). When riprap is placed underwater, the thickness of the riprap layer should be increased by 50 percent. A filter layer is placed under the riprap so that fine material from the streambed is not washed out through the openings in the larger stone. Either a fabric filter or graded aggregate filter can be used. Graded aggregate filters placed underwater should have a minimum thickness of 12 inches.

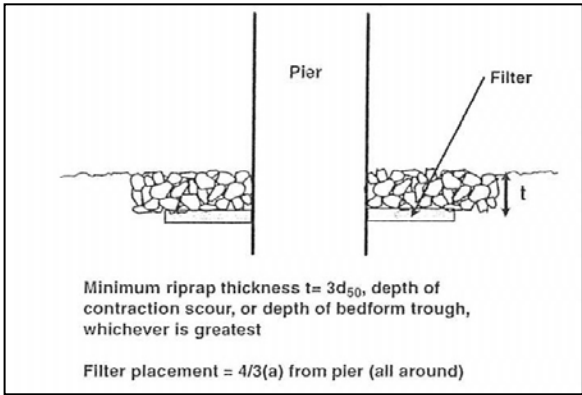

Figure 7-14 Riprap Section

Stone for riprap must be durable and rectangular, with a length to thickness ratio less than three. Riprap should be installed so that the top of the riprap is even with the top of the footing. Otherwise, an additional obstruction to flow is created.

The area to receive riprap is first excavated to the required depth and area. The filter layer is then placed. Fabric filter cloth may be difficult to place underwater unless

flow is negligible. The fabric can be rolled out and staked to the streambed to secure it prior to placing stone. Fabric should be loosely laid with generous overlaps at edges. Stone should be carefully placed to prevent tearing of the filter. Stone filters should be graded to uniform thickness. The filter should not extend to the outer edge of the riprap, but should tightly enclose the pier. Riprap placed on an embankment slope at an abutment should have the toe buried beneath the streambed, though an alternate installation places a mound of stone along the toe rather than burying it.

7-7.2.2 Grouted Riprap

Grouted riprap is primarily used for stream bank slope protection. It provides a smoother hydraulic surface than standard riprap, and allows use of smaller sized stone. Filter fabric should be placed under the stone and weep holes are required to relieve the buildup of hydrostatic uplift pressures. Details on design and placement can be found in HEC 11 and HEC 23.

7-7.2.3 Articulated Blocks

Articulated concrete block systems (ACBs) consist of precast concrete units that interlock or are tied together by cables in order to act as a continuous mat system. These systems have predominately been used for slope protection (Figure 7-15), but are also applicable to pier and abutment scour protection.



Figure 7-15 Articulated Concrete Block System Being Installed

Details of ACBs vary among manufacturers. System design is discussed in HEC 23, Design Guideline 4. Parameters used in design are developed by manufacturers based on product testing.

When using ACBs for scour protection, mats that are preassembled and secured by cabling are recommended. Installation of ACBs for pier scour protection includes the following:

- The ACB mat should extend at least 2.5 times the pier width in all directions.
- The top of the mattresses should be even with the streambed. The upstream edge of the mat should be turned down and buried.
- A filter layer must be used below the ACBs.
- No gaps should be left between individual ACB mattresses.

- Mats must be sealed at the pier. Techniques used to provide a seal include grouting or concreting the gap, placing grout bags at the joint, and sealing filter fabric to the pier (or pile) with banding.
- Installation of anchors through the mat into the streambed around the mattress edges counteracts any tendency of the mattresses to be lifted by currents. Duckbill anchors placed at 8 feet spacing and corners have been used by the Minnesota Department of Transportation. Screw-in anchors can also be used.

As with riprap, ACB systems should be inspected following major storm events to assure proper performance.

SECTION 8. FOUNDATION MODIFICATIONS

7-8.1 General

Existing bridge foundations may require modification to support added loads or to develop resistance to anticipated scour conditions. This work has traditionally been executed inside of dewatered cofferdams. However, use of underwater construction techniques may allow this work to be completed without cofferdam installation. Foundation modifications most often include installation of new piles, and extension of the pile cap and pier shaft.

7-8.2 Pile Installation

Driven piles, drilled shafts, or micropiles can be used to increase foundation capacity. Installation of driven piles or casing for drilled shafts may not be feasible due to limited headroom under the bridge. Micropiles are placed in sections and readily installed in low headroom conditions.

If the foundations to be modified are already pile supported, there may not be room to add additional driven piles or drilled shafts within the existing pile group. Piles can be added outside the existing cap and the cap extended; however, this will increase cap bending stresses and may require extensive cap strengthening. While such strengthening could be performed under water, use of cofferdam methods is generally preferable.

For spread footings, holes can be cored through the footing and piles driven, drilled, or pushed through the holes. Figure 7-16 illustrates the use of piles—micropiles are shown—to extend foundation support into material below the design scour depths. After pile installation, the opening in the footing is filled with concrete or grout. Shear studs and local reinforcing may be needed to properly transfer the pile loads to the footing. Micropiles are well suited to foundation strengthening or modification projects. Advantages of micropiles include their small diameter, ability to be installed in low headroom conditions, high load capability, and installation procedures that do

not create significant vibrations to affect the existing structure. Micropiles can be installed as batter piles as well as vertically.

7-8.3 Footing or Pile Cap Extensions

Constructing footing or pile cap extensions underwater is completed in a similar fashion to above water construction. Figure 7-17 illustrates a cast-in-place modification to a pier nose to reduce flow resistance and scour depth. Drilled and grouted reinforcing steel is placed to secure the old and new construction. Either rigid panel forms or stiffened fabric forms, which would remain in place, can be used to form the extension. Reinforcing steel is assembled above water and set in the maximum size sections that can be handled. Since silts and other deleterious materials can collect on the reinforcing, concrete placement should commence immediately after the reinforcing is set. Dowels may require presetting prior to primary reinforcing placement. Concrete can be placed by pumping or tremie. Pumping or an inclined tremie are preferable unless the extension is quite thick. Concrete must be flowable and preferably self leveling as vibration is not possible unless the forms extend above water and are well sealed to allow dewatering. To account for the accumulation of laitance atop the concrete, it is prudent to allow for several inches of “waste” concrete when sizing the footing thickness.

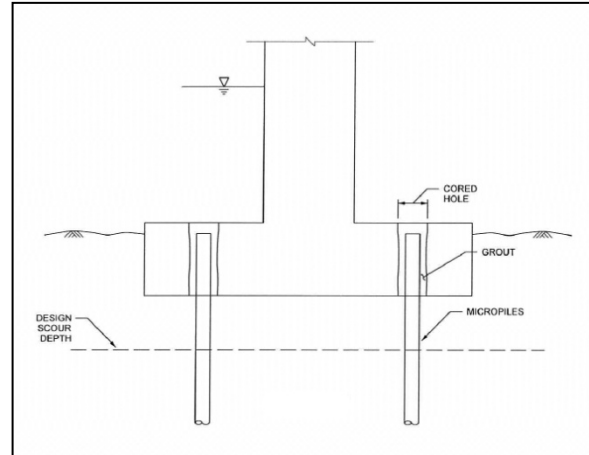

Figure 7-16 Footing Modification Using Micropiles

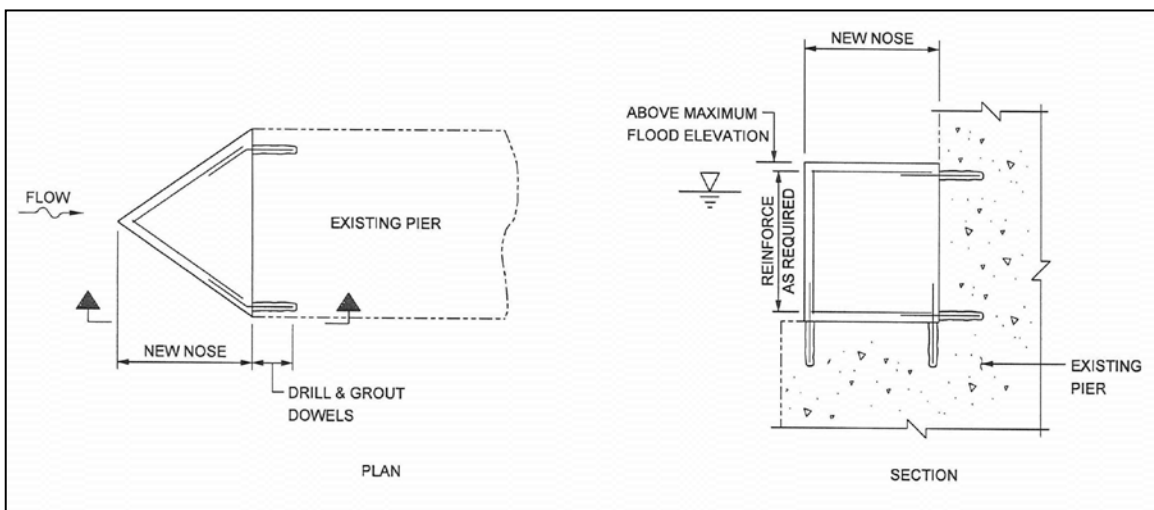

Figure 7-17 Modification to Pier Nose

CHAPTER VIII PILE and SHEET PILE REPAIRS

SECTION 1. INTRODUCTION

Pile supported bents are a common type of bridge substructure. Steel H-pipes and pipe piles, reinforced and prestressed concrete piles and timber piles are all found in existing structures. Sheet piles are found in river walls and bridge protective structures.

The high surface area to volume ratio of piles increases the rate of deterioration. Piles are also subject to physical damage, particularly where they form part of bridge protection systems.

Pile repair technologies range from replacement and installation of supplemental piles to a wide range of pile wraps and jackets. Repairs can restore strength and provide added protection from further deterioration. Good repair performance requires careful selection of repair techniques and use of proper installation methods.

SECTION 2. PILE REPAIR

Selection of an appropriate pile repair scheme must consider the types and extent of pile deterioration or damage. Repair options include splash zone/underwater applied coatings, pile wraps, pile jackets, and partial or full pile replacement. Coatings and pile wraps provide a protective barrier against water (and the salts and chemicals it may contain) and marine organisms. Pile jackets provide protection, but can also provide restoration of capacity by incorporating reinforcing within the system. These techniques are discussed further later in this chapter.

Pile wraps and jackets are generally selected by the repair designer based on engineering judgment and experience. Research on pile jacket strengthening and performance is extremely limited. Though some data on composite usage may suggest otherwise, no pile jacket repair technique other than cathodic protection (Chapter IX) should be considered to prevent corrosion. One of the problems posed by the installation of pile jackets, and to a lesser extent pile wraps, is the inability to inspect the actual pile condition once the jacket or wrap is in place.

Where pile physical damage is extensive, or where deterioration is the result of inherent materials problems such as alkali-silica reactivity or delayed ettringite formation, pile replacement may be the only viable repair method. It may be possible to “rebuild” the pile in place by means of a reinforced pile jacket or composite jacket

with sufficient strength in itself to carry the full pile load. Figure 8-1 summarizes pile repair methods and provides general “rules of thumb” on their usage.

DAMAGE	REPAIR OPTION
Steel	
<15% section loss	Coatings, pile wrap
15-30% section loss	Pile jacket
>30% section loss	Pile jacket with reinforcement
	Partial replacement
Concrete	
No visible deterioration	Pile wrap
Corrosion damage:	
<15% reinforcing loss	Pile jacket
>15% reinforcing loss + spalling	Pile jacket with reinforcement
Material deterioration (ASR, DEF)	Pile jacket with full capacity reinforcement; pile replacement
Timber	
Rot, abrasive damage, surface defects, <15% section loss	Pile wrap
Deterioration, borer attack, 15-50% section loss	Pile jacket with reinforcing
>50 section loss	Partial or full length replacement
<i>This table presents general suggestions relating deterioration to possible repair methods. This data must be used with engineering judgment and analysis.</i>	

Figure 8-1 Possible Repair Methods as They Relate to Deterioration

Costs of pile repair techniques vary widely. Factors effecting costs include the repair type, extent of pile cleaning required, extent of pile deterioration and preparatory work needed before wrap or jacket installation, water conditions, local experience of contractors, size of project, etc. As an approximated relative cost guide, pile wraps are the least costly option (assuming that they are an appropriate repair method). Concrete/Portland cement pile jackets cost approximately three times the cost of pile wraps, and polymer jacket systems cost approximately six times the pile wrap cost. Pile replacement is generally the most costly alternative.

SECTION 3. PILE REPLACEMENT

Piles with severe physical damage—for instance, broken piles—or those subject to material degradation such as delayed ettringite formation may not be repairable. Extensive deterioration may necessitate repairs that are not economically viable. In these cases, pile replacement may be utilized. Direct pile replacement is not normally possible due to difficulties of removing the existing pile. One exception to this is bridge protective systems such as shear fences where pile removal and replacement may be readily accomplished, or an adjacent new pile added and the existing pile abandoned. Piles used for replacement should conform to agency specifications for new construction. Generally, replacement piles are of a similar type to those they replace.

In some cases a supplemental pile can be driven next to the deteriorated pile (Figure 8-2). The existing pile cap and bracing must be modified to assure load transfer to the new pile. Supplemental pile bents, often called crutch bents, can be used where the existing pile cannot be directly replaced. The old pile is not actually replaced, but new piles driven to either side of the damaged pile take over its load carrying function. Figure 8-3 shows a typical crutch bent, Figure 8-4 shows a crutch bent under a pile bent cap. The supplemental piles can normally be driven through openings cut into the bridge deck. Either steel or concrete can be used for the cap connecting the supplemental piles. A preload equal to the dead load carried by the pile(s) may be created in the supplemental bent by jacking between the existing cap and new piles prior to installing the supplemental pile cap. The existing pile cap must be analyzed for the new support conditions. If needed, the original pile cap can be strengthened.



Figure 8-2 New Pile Driven Outside of Damaged Pile

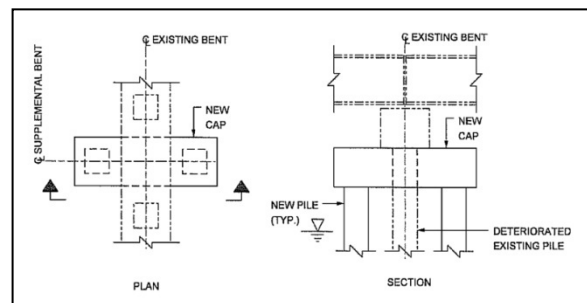

Figure 8-3 Supplemental Pile Bent



Figure 8-4 Supplemental Pile Bents (Crutch Bent)

SECTION 4. PARTIAL REPLACEMENT

Partial pile replacement or splicing can be used when a localized area of pile is severely damaged. Partial replacement has predominately been applied to timber piles though it is used to a limited extent on steel piles. Various partial pile replacement details are shown in bridge repair references. In any partial replacement, proven vertical and lateral load transfer must be provided through selection of the installation details and possible added bracing in the bent. The development of various pile jacket systems has reduced the use of partial replacement. Partial replacement may require use of a temporary support to maintain bridge support during removal of a portion of pile.

Figure 8-5 shows one technique for partial replacement of a steel pile. The damaged area is cut off and a bearing plate installed atop the remaining lower pile section. The bearing plate can be bolted or welded to the existing pile. The new upper portion is installed by bolting or welding to the bearing plate installed on the lower section. To account for installation clearances the replacement is fabricated to be shimmed at the existing pile cap. The pile may be preloaded by jacking the pile against the cap prior to shimming.

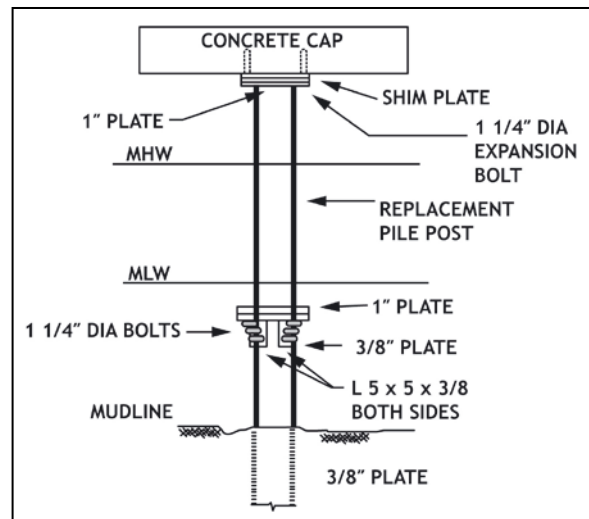

Figure 8-5 Partial Steel Pile Replacement

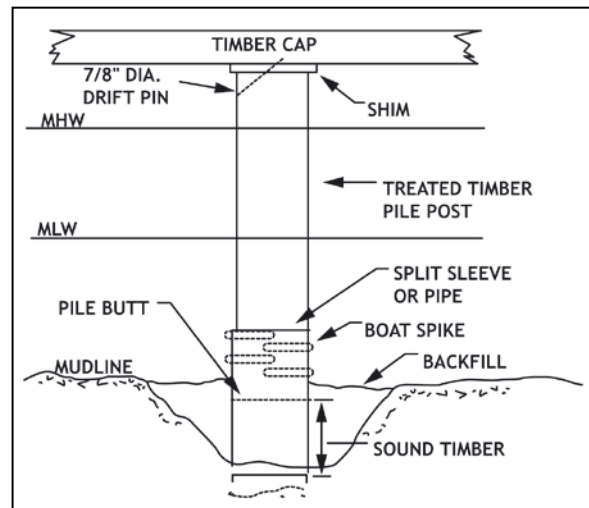

Figure 8-6 Timber Pile Replacement

A method for splicing a portion of timber pile is shown in Figure 8-6. A steel sleeve is set over the bottom remaining section of pile to receive the new section. This sleeve is secured with spikes and grout and is placed between the pile sections to aid in transfer of load from the new to existing pile sections. The top of the replacement section is shimmed tight. Various fasteners or an epoxy grout could also be used at the top connection. Another method of splicing in a new pile section using splice plates, or "fish" plates, is shown in Figure 8-7. For all partial pile replacement schemes, the new sections must be adequately tied to the structure for lateral support using existing and supplemental bracing. Partial replacement of more than one pile in a bent is not recommended. The AREMA Manual for Railway Engineering,

Chapter 7, limits the number of posted timber piles to one in a four pile bent, two in a five pile bent, and three in a bent of six or more piles. It further recommends that outside piles over 12 feet high on curves, or 23 feet on straight bridges not be posted.

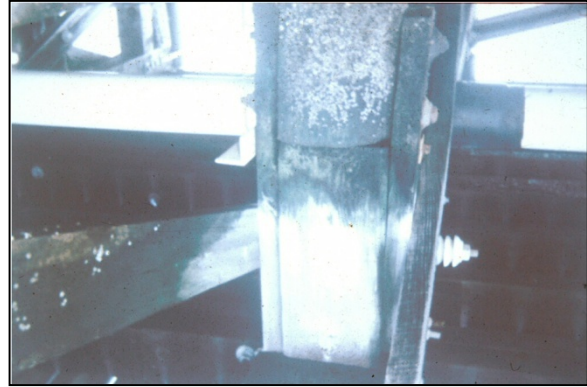

Figure 8-7 Pile Replacement Using Splice Plates

SECTION 5. PILE WRAPS

8-5.1 Description and Purpose

Pile wraps are installed on piles to provide protection from further deterioration. Unlike pile jackets (discussed later), they do not allow for any restoration of pile load capacity. Pile wraps are membrane systems that form a barrier between the pile and water, and their proper installation is important for achieving expected performance. Pile wraps have been primarily used on timber piles, but can be used on other pile types as well.

Pile wraps are made from polyvinyl chloride (PVC) or similar sheet materials and incorporate various proprietary details for vertical seams and securing the wrap to the pile. Some systems incorporate an inner layer of felt-like material saturated with various chemicals to aid in securing a good fit or in protecting the pile. When used on steel piles, this inner layer may contain corrosion inhibitors. In service, the pile wrap prohibits the exchange of water between the inside of the wrap and the surrounding water. Thus, oxygen and deleterious chemicals can no longer reach the pile. When used on timber piles, this eliminates the source of nutrients and creates an anaerobic condition within the wrapped pile that causes wood destroying marine organisms within the pile to die.

8-5.2 Advantages and Disadvantages

Advantages of pile wraps for pile protection include the following:

- **Cost**—Pile wraps are less costly than pile replacement or installation of pile jackets.
- **Minimal Equipment**—Pile wraps can be installed by divers without the need for above water hoisting capabilities, concrete pumps, and similar equipment. Equipment for pile cleaning may be required.
- **Chemical Resistance**—Materials used for pile wrap are resistant to most chemicals that might be found in polluted water. For severe applications, manufacturer test data should be reviewed.

Disadvantages include the following:

- **Ultraviolet Attack**—Pile wrap materials are normally polymer sheets that are subject to attack by ultraviolet light. This can cause chalking and embrittlement for portions of the wrap exposed to sunlight. Ultraviolet inhibitors are used by manufacturers to minimize those effects.
- **Abrasion**—Wrap materials may be abraded by sand and silts carried by moving water or resulting from prop wash. Abrasion is most severe near the streambed. Pile wraps that are thick or of reinforced polymers can provide increased resistance.
- **Physical Damage**—Impact from boats or water born debris and ice can cause tears in the materials rendering the wraps ineffective.

8-5.3 Design Considerations

Pile wraps must be installed at early stages of deterioration where loss of structural capacity is not significant, or before deterioration begins. For marine borer repair/protection, the U.S. Navy guidance is to install pile wraps before 5 percent pile section loss has occurred. Their use at up to 15 percent loss is allowed; above this, use of reinforced concrete jackets is recommended. Application of pile wraps to steel piles should be based on a load analysis to determine an acceptable loss of pile section.

The wrap is installed just prior to reaching this section loss, based on field measurements. For concrete piles, wraps must be in place before chloride concentrations reach a level sufficient to initiate reinforcing corrosion. When installed on timber piles as marine borer repair or protection, the wrap should extend from above high water elevation to two feet (minimum) below the seabed. When used to protect steel or concrete piles the wrap must extend above the splash zone and at least several feet below low water.

Pile wraps are available in varying thicknesses with 0.03 inch (30 mil) and 0.06 inch (60 mil) most common. The thicker material is recommended due to better resistance to physical damage and abrasion and an extended service life. Aluminum ring shank nails are usually used to secure the wrap seams on timber piles. When wrapping piles treated with CCA or similar preservations, bronze or stainless steel nails should be used to prevent deterioration of the nails by the preservatives. When PVC wrap material is to be installed on creosote treated piles, a layer of polyethylene sheet should first be placed around the pile to prevent deterioration of the PVC wrap by the creosote. In place of nails, some manufacturers use clamp type arrangements to make up the vertical seams. Some of these allow removal and reinstallation of the pile wrap, which enables inspectors to examine the pile beneath the wraps and verify future proper performance. All metal fastening bands and hardware should be stainless steel.

8-5.4 Installation

Details of installation will be dependent upon the particular wrap utilized, with the primary variations being the method of seam fastening. Manufacturer's installation requirements should be strictly followed.

The initial step in installation is to clean the pile of all marine growth, sediments, and old hardware or attachments which could damage the wrap or inhibit attaining a tight fit to the pile (Figure 8-8). Pile wraps and fastening components should be inspected for tears or other defects prior to installation. The wrap is attached using the supplied fastening system, assuring a tight fit. Typically a stainless steel band around the pile is used at the top and bottom seals. A cellular foam filler can be placed between the pile and wrap to aid in sealing. When pile surfaces are deteriorated or damaged, an epoxy mortar can be used to even out the pile surface under the foam filler. Pile wraps composed of several lengths should be overlapped and sealed at the horizontal joints. Figure 8-9 shows wraps being installed, including horizontal seams. The top banding is shown in Figure 8-10. This system used nails to secure the vertical seam. Note that the wraps are tight, that the brace is wrapped separately, and that a new galvanized bolt has been installed. Figure 8-11 shows another example of good practice where the piles and splice members have been wrapped individually.

For systems that utilize an inner layer of protective material (Figure 8-12) the inner layer is placed over the cleaned pile and secured before installing the outer wrap. Some multilayer systems use a gel-like under layer applied by hand.

Quality assurance inspections during installations should assure proper pile preparation and that wraps are installed without tears or other damage and with tight seams and seals to prohibit water from working its way inside the wrap.



Figure 8-8 Pile Cleaning



Figure 8-9 Pile Wrap Installation

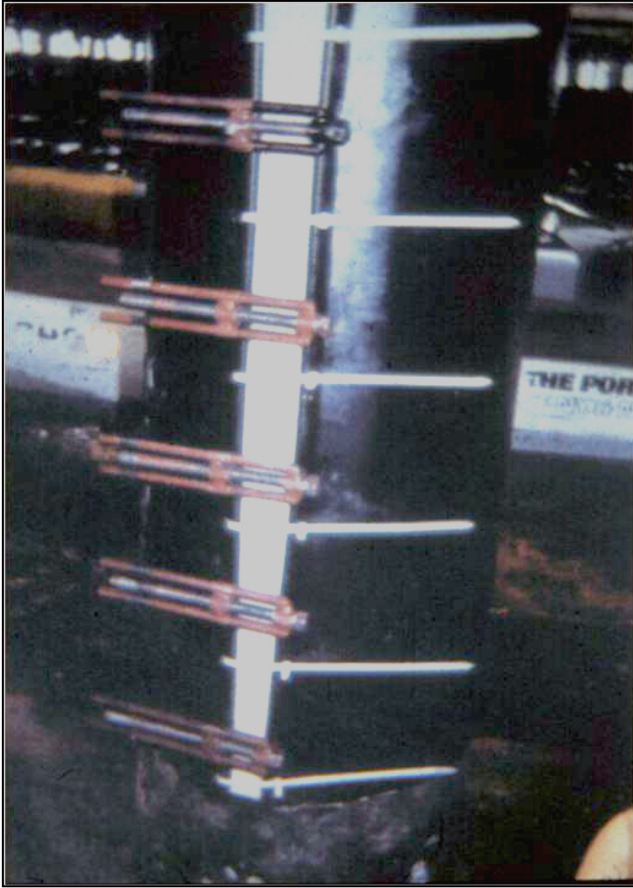

Figure 8-10 Pile Wrap Attachment

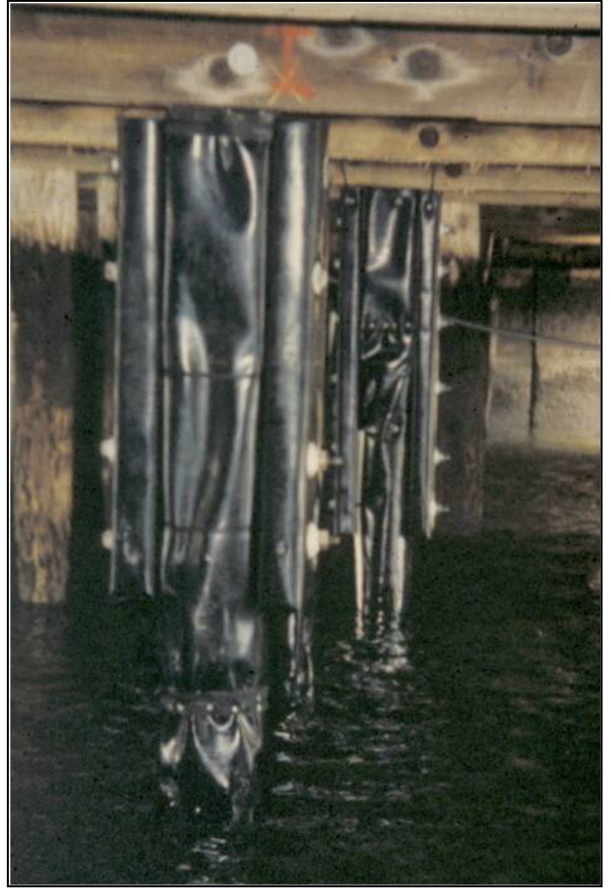

Figure 8-11 Wrap Installation at Pile Splice



Figure 8-12 Cutaway of Wraps with an Interim Protective Layer. The Wrap Uses a Proprietary Clamp Closure System

SECTION 6. PILE JACKETS

8-6.1 Description and Purpose

Pile jackets consist of a concrete, Portland cement grout or polymer grout encasement placed around a pile to provide protection and restore structural capacity. Jackets may extend over the pile length, or part of its length. They are usually used on piles that have experienced damage or deterioration. A wide variety of product types are available, many of them proprietary systems (Figure 8-13). Systems that utilize polymer grouts generally include a stay-in-place polymer form system.



Figure 8-13 Typical Fabric Bag Concrete Pile Jacket on Timber Pile

8-6.2 Advantages and Disadvantages

Pile jackets are more expensive to install than pile wraps. However, they can provide several advantages in addition to providing a protective barrier. Pile jackets include a forming system and grout or concrete fill into which reinforcing can be placed. The combination of the grout plus reinforcing provides structural load carrying capacity in the pile jacket. Some types of stay-in-place forms also add strength. For severely damaged piles, jackets essentially allow piles to be reconstructed in place.

Potential disadvantages to using pile jackets include the following:

- Pile size—Depending upon the system used, pile jackets will increase the pile diameter from around two inches to 6 or 8 inches. The added size increases pile self weight and creates higher lateral current or wave loads.
- Seismic response—Pile jackets stiffen the pile, and thus attract lateral load during seismic events. Since pile jackets may be present over only partial pile lengths and not be on every pile, pile bent analysis may be more complicated.

8-6.3 Design Considerations

In most cases pile jackets are “selected” based on requirements such as wanting a minimal pile size increase or concerns with installation temperatures rather than actually designed. When piles are severely deteriorated it is recommended that calculations be performed to determine the amount of reinforcing to be placed into the jacket. If the damage is localized along the pile length, and only a local repair planned, the jacket must extend a sufficient distance above and below the damaged area to provide load transfer from the pile, to the repair, and back into the pile.

All materials must be selected to provide a durable repair. Fiberglass stay-in-place forms used with epoxy grout are designed to function as a bonded, integral system. The form must not deteriorate from the effects of water or ultraviolet rays. Ultraviolet attack is very severe in marine conditions. Glass reinforcing fibers that come into contact with sea water swell and cause degradation of the form. Ultraviolet blockers and overcoating of forms with a resin layer will enhance form durability.

Pile jacket systems fall into two broad categories: non composite systems in which the jacket form simply serves to retain the concrete or grout until it gains strength and is then removed or allowed to deteriorate, and those in which the jacket form and polymer grout are intended to act as a composite system. Particular aspects of each type are addressed in the following sections.

8-6.4 Installation of Noncomposite Systems

Forms for noncomposite systems may be fabric, flexible fiberglass stay-in-place or removable, or rigid forms similar to those used for standard bridge columns. Fabric forms are inexpensive and easily handled. Disadvantages of fabric forms include a tendency to degrade above water due to ultraviolet attack. This has no structural significance as the forms serves no purpose once the grout/concrete has cured, but may yield a poor appearance. The form flexibility makes it difficult to maintain an even grout thickness, particularly when used on batter piles. This problem can be reduced through generous use of spacers to control the distance between the pile and form. The form fabric and closures, usually zippers, must be able to withstand the pressures due to grout filling, which can be substantial for long piles. The design of flexible fiberglass or standard forms is similar to standard column form design.

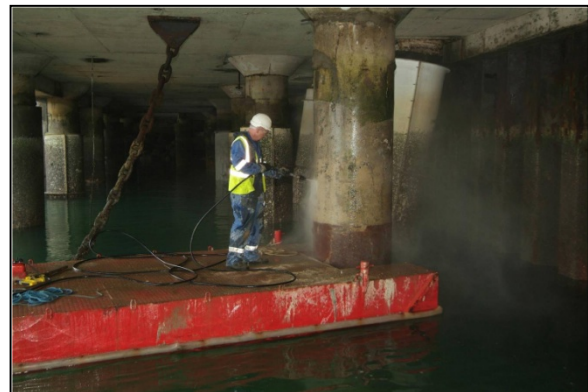

Figure 8-14 High Pressure Water Cleaning Prior to Pile Jacket Installation

The initial step in jacket installation is to clean the pile of marine growth and deteriorated pile material. High pressure water is commonly used (Figure 8-14). For concrete filled jackets that are several inches thick, it may be permissible to allow some tightly adhering barnacles and similar marine growth to remain on the pile surface. Loose corrosion products should be removed. The next step is to place form spacers (Figure 8-15). The number of spacers will depend upon the jacket type, with rigid forms requiring fewer spacers than fabric forms. Reinforcing steel is set using spacers as required. The amount of reinforcing will depend upon pile strength requirements. However, a minimal reinforcing of welded wire fabric is recommended for volume change crack control and general repair integrity. Fabric forms are

generally hung from above (Figure 8-16). Other types of forms may be hung also after assembly, or support on a platform secured to the pile using clamps.



Figure 8-15 Formwork Spacers in Place



Figure 8-16 Fabric Form Installation

In order to better control the potential deformations of fabric forms, or similar flexible forms, a stiffening system is sometime placed around the form as shown in Figure 8-17. In this case the stiffening consists of vertical reinforcing bars connected with a geogrid material. The grout or small aggregate concrete must be placed from the bottom up and evenly distributed around the pile so formwork is not displaced by uneven pressures. Material can be pumped into ports starting at the base of the form (Figure 8-18), or by tremie placement. Adequate grout must be available to allow uninterrupted placement. Back-up equipment should be available. A completed jacket is shown in Figure 8-19. Jackets may also be installed completely underwater as seen in Figure 8-20.

A semi-rigid form (Figure 8-21) is used in a similar manner to the fabric forms and remains in place. The form seams are connected using epoxy paste and pop rivets or self drilling screws. This form type is easy to handle and retains its shape.

Figure 8-21 shows a rigid form being set. Valves are set into the base of the forms and at vertical intervals along the form so grout can be pumped in from the bottom up. Installation must assure that valve and reinforcing steel location is coordinated so

that the reinforcing bar is not directly behind a flex type valve, preventing it from fully opening. These forms are removed once the grout has cured. Rigid form systems can produce pile jackets with a finished appearance.

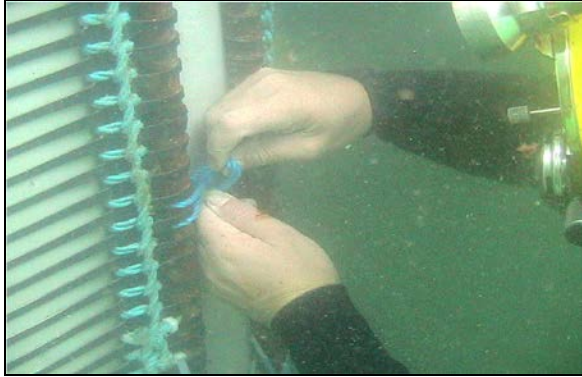

Figure 8-17 Stiffening System Being Secured in Place

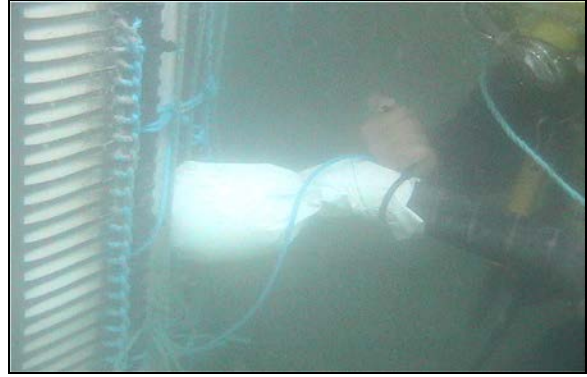

Figure 8-18 Pumping Grout into Form



Figure 8-19 Completed Fabric Form Jacket



Figure 8-21 Semi-rigid Stay-in-Place Form; Note Also the Reinforcing Cages Sit Awaiting Forms



Figure 8-20 Completed Underwater Fabric Form Repair

8-6.5 Installation of Composite Systems

Composite pile jackets are composed of a stay-in-place fiberglass form and an epoxy grout (Figure 8-22). Adhesion of the grout to both the concrete and form is important to the overall composite performance. The systems are generally about 1 inch thick which reduces added pile weight and effective area for current or wave loads. Reinforcing can be placed within the form if required. Epoxy materials possess properties that differ from the pile material. No matter how high their strength, the lower modulus epoxy materials will not carry a proportionate part of the load when acting with a stiffer concrete or steel pile.



Figure 8-22 Completed Composite Jacket (Back Pile) and Jacket Read to be Pumped (Middle Pile). The Stiffening System is in Place on the Middle Pile Due to the Flexibility of the Fiberglass Jacket Form.

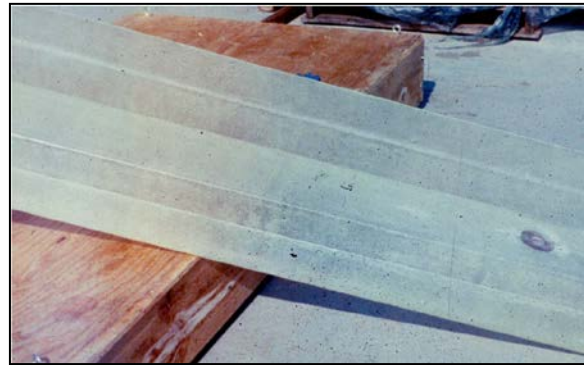

Figure 8-23 Composite Pile Jacket Form; Note Form Translucence and the Injection Port of the Right Hand End

The epoxy grout should be a 100 percent solid epoxy, and usually contains mineral fillers or silica sand. It must be formulated for underwater use and be readily pumpable and flowable.

Most manufacturers recommend grout placement immediately after pile cleaning in order to maximize grout bond. A two step cleaning process is often used since marine growth or suspended materials in the water may rapidly contaminate the pile surface. The primary cleaning removes marine growth and all loose and deteriorated pile materials. Immediately prior to positioning the form, a second cleaning by high pressure water is completed. The inside surface of the forms is also prepared by light abrasive blasting, or sometimes removal of protective coverings to enhance grout bond to the form. Translucent forms facilitate diver inspection of grout placement (Figure 8-23).

Grout placement must progress from the bottom up in a continuous placement. Grout can be pumped into ports in the base of the form, or be placed through vertical pipes inserted between the form and pile, similar to a tremie (Figure 8-24). Adequate back-up equipment should be available to assure uninterrupted placement.

8-6.6 Quality Assurance

Proper planning and regular construction observation is needed to assure proper pile jacket installation. Problems are often not detected until the jacket is completed. Chapter X addresses construction inspection.

Figures 8-25 and 8-26 show results of poor construction practices. While the displaced pile jacket in Figure 8-25 is still providing at least some protection to the original pile, the pile jacket in Figure 8-26 has failed. For large or complex projects, test installations may be warranted. Figure 8-27 shows removal of a test pile jacket to verify proper construction. Core samplings (Figure 8-28) and pull-off tests can be performed to test for proper surface cleaning, grout placement, and bond of the grout to the pile or jacket form. Composite pile jacket systems typically require a bond strength between the polymer grout and pile surface of 150 psi, though the manufacturer's literature should be reviewed for their specific requirements. Bond testing can be performed both above and below water utilizing a Modified Elcometer Test method.



Figure 8-24 Epoxy Placement Pipes in Form



Figure 8-25 Displaced Fabric Formed Pile Jacket Due to Lack of Spacers and Uneven Grout Placement

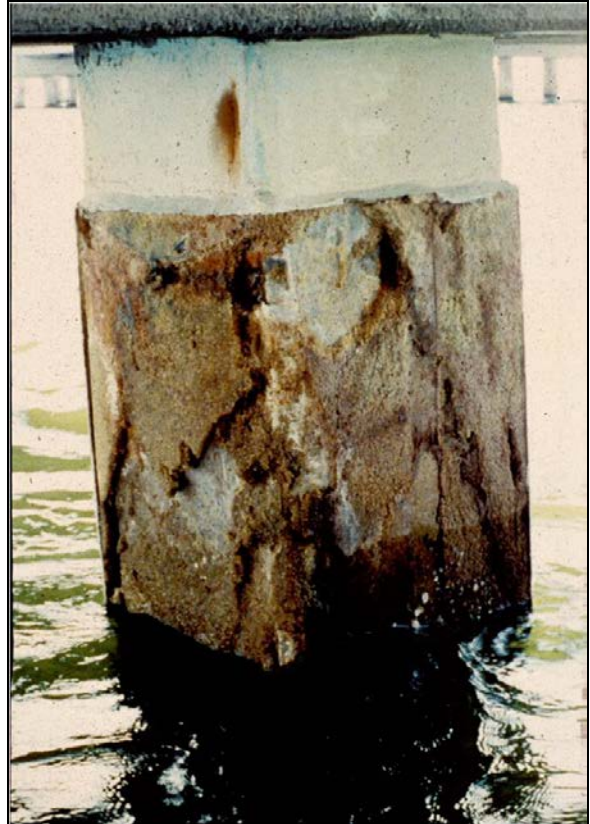

Figure 8-26 Composite Jacket with Missing Form Due to Poor Bond and Grout Placement; Note Void Areas in Grout



Figure 8-27 Removal of Pile Jacket to Verify Installation Procedures

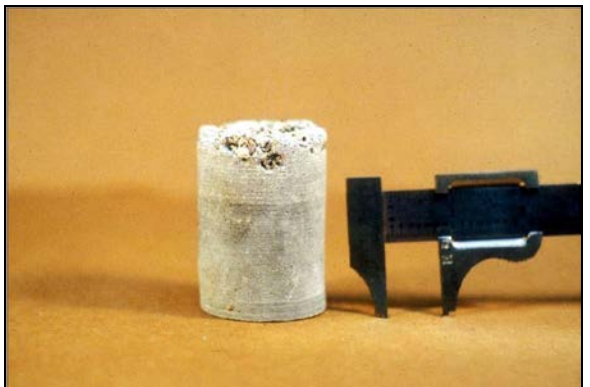

Figure 8-28 Core Through Pile Jacket Showing Marine Growth Remaining Under Grout

SECTION 7. COMPOSITE STRENGTHENING

8-7.1 Materials and Properties

The repair and strengthening of structures by use of bonded fiber-reinforced polymer (FRP) has expanded over the past few years. This technique has been utilized in repair and strengthening of piles both above and underwater. The technique is well suited to providing increased strength and concrete confinement for seismic requirements (Figure 8-29).



Figure 8-29 FRP Strengthening of Concrete Piles and Pile Cap

Design of FRP strengthening should be in accordance with the provisions of ACI 440.2 and NCHRP Report 514. Design is sometimes provided by the FRP system supplier. By controlling the resin properties and the fiber type and orientation, FRP systems can be tailored to specific strengthening applications. Glass and carbon fiber with epoxy resins are commonly used.

When FRP is used to strengthen piles with active corrosion, consideration should be given to the potential for future corrosion within the strengthened area. ACI 440.2 guidelines caution that installation of FRP systems does not stop ongoing corrosion. Engineers do not agree on whether a polymer can achieve complete bond to a porous saturated concrete surface. The use of FRP in underwater repairs is relatively recent and long term performance information is not available.

8-7.2 Installation

Installation procedures and details will vary with specific manufacturer's products and requirements. Concrete surfaces to receive FRP materials should be cleaned to remove all marine growth and deposits and deteriorated concrete. Local concrete repairs may be needed so that the FRP material is adequately supported and to assure that the substrate can withstand the resin bond stresses without surface failure. To facilitate fiber placement and prevent material damage, sharp corners should be ground smooth.

A resin layer is applied to the prepared surface, typically by a gloved hand or a roller. The reinforcing fabrics are pre-impregnated with resin above water and taken underwater for placement. The reinforcing fabrics may be in the form of sheets or rolls. When water activated resins are used, the impregnated fabrics can be taken underwater in sealed bags to delay the onset of curing.

Prefabricated jackets are sometimes used as the reinforcing system. These contain fiber reinforcing in a predetermined configuration. The seams are joined with stainless steel screws and epoxy, and the annulus filled with an epoxy.

Application of FRP materials involves numerous materials safety considerations. Contractors must have specific training in product safety and installation, and are often licensed by the manufacturer.

SECTION 8. CRACK INJECTION

Crack injection can be used for repair of cracks in concrete piles. Crack injection materials and process are presented in Chapter VII, and are executed in the same manner for pile repair. Only dormant cracks should be injected.

SECTION 9. COATINGS

Commercially available coatings formulated for underwater and splash zone applications are available. These are most often used on steel H-piles, pipe piles, and sheeting, but may also be used on concrete. They form a barrier coating to prevent contact with the water. When used on concrete they must be applied before the chloride level at the reinforcements reaches the critical value to initiate corrosion. These coatings are generally epoxy or polyester formulations. Some materials are quite viscous and are applied by gloved hand or trowel. Others can be applied by brush or roller. Coatings can be applied to concrete or steel. The U.S. Army Corps of Engineers recommends that the coating material exhibit a minimum adhesion strength to sandblasted steel of 560 psi for a brushable product.

Surfaces to receive underwater applied coatings should be prepared by abrasive blasting to remove all deleterious material and provide a surface profile to maximize adhesion. The materials are mixed and taken underwater in a bucket, though pressurized hoses feeding a roller have been developed by some contractors. Material application by gloved hand or trowel typically results in a coating thickness of .125 .200 inches. Brush or roller applied coatings are typically .03 to .04 inches thick. The complications of using epoxies underwater discussed in Chapter 4 apply to coatings as well. Coating materials should be free of harmful chemicals that could enter the water. A documented history of successful use should be required from the product manufacturer and applicator.

Coating inspection should include verification of surface preparation, materials preparation and application, and selected coating thickness readings of the completed work. Magnetic coating thickness gauges may be used underwater.

Properly applied underwater coatings can be expected to have a service of 8 to 10 years, possibly more. Periodic recoating should be programmed.

SECTION 10. SHEET PILE REPAIRS

Sheet pile repairs are made as a result of sheet pile corrosion or due to physical damage from vessel impact or floating debris. The use of timber and concrete sheet piling in bridge structures is limited, and thus only steel sheet piling is addressed in this section. However, repairs to concrete sheet piling can be performed in a manner similar to pier repair techniques. Overall failure of sheet pile walls (Figure 8-30) is most often a geotechnical failure requiring wall reconstruction. The AASHTO design specifications and various FHWA publications provide requirements for new walls.



Figure 8-30 Sheet Pile Wall Failure

8-10.1 Corrosion

Minor loss of section due to corrosion can be repaired by application of splash zone and underwater coatings (see Section 9). This may be considered a maintenance activity, and periodic recoating should be anticipated. Temporary cofferdams can be used to allow repair and coating to be completed in dry conditions. Some contractors have constructed specialized limpet cofferdams to fit sheeting profiles. Cathodic protection may also be installed and is discussed in Chapter IX.

Local areas of severe section loss, including holes, can be repaired by installing patch plates. Patch plates can be attached to the sheet piles by welding or bolting. When bolting, a slotted hole is made and “tee” bolts or hooked bolts used to fasten the patch plate. Fastener holes should be located in areas of near full steel thickness. Voids behind holes can be packed with stiff concrete prior to installing the patch plate.

Extensive deterioration may require replacing the wall or installing a concrete facing. New walls are placed just in front of the existing wall. This simplifies construction. Keeping the face of the new wall within two feet of the existing sheeting normally can expedite permitting under the Corps 404 requirements. New walls are often

reconnected to the existing anchorage system; however, the system should not be reused unless a condition assessment and analysis is completed. This will usually require partial excavation of the anchorage system.

Figure 8-31 shows a typical concrete facing wall. The bottom form is cut to fit the sheet pile profile. When sealed to the sheets, the area can be pumped out to allow placing the reinforcing and concrete under dry conditions, or the form may be left with water and tremie placement used. The outside concrete should extend at least two feet below low water.

8-10.2 Damage Repair

Damaged sheets are usually pulled, and new sheets driven in their place. Many older sheet pile profiles are no longer available, and existing interlock configurations may not match available replacement sheets. When interlocks differ, an existing good sheet can be pulled, the sheet cut lengthwise, the interlock cut off the new sheet, and the old section of sheet with the interlock is welded to the new, interlockless, sheet. This creates a sheet to interlock with the existing and new sheets.

Cellular sheet pile bridge protection cells are normally filled with granular material. Pulling damaged sheets will cause loss of fill that may not be acceptable. In some cases clearances may be sufficient to allow driving a new cell around the old one, though this is a costly option. Where damage is restricted to dented or locally torn sheets, a steel band can be used to limit further damage (Figure 8-32). The bands are fabricated in two or more sections and fastened together with rods and nuts. Bands are readily placed above or underwater. The bands are designed to withstand a tension load equal to the interlock tension capacity of the cell sheets.

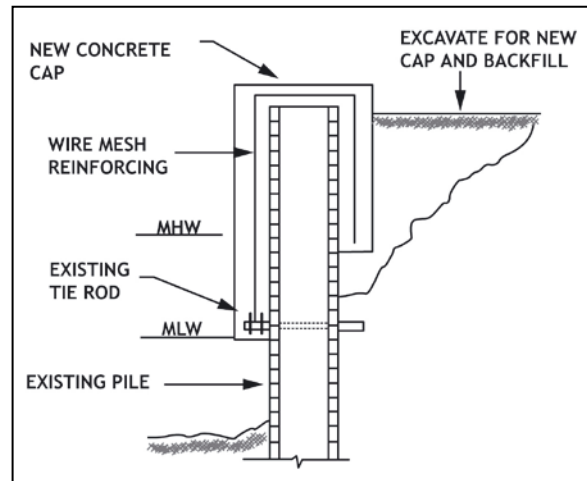

Figure 8-31 Facing Repair Concept

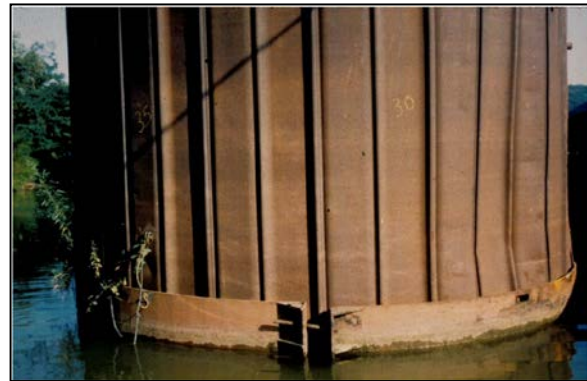

Figure 8-32 Reinforcing Band Placed on Sheet Pile Cell

CHAPTER IX CATHODIC PROTECTION FOR SUBSTRUCTURES

SECTION 1. INTRODUCTION

In the design of new structures various techniques are used to delay the onset of corrosion such as dense concrete, adequate concrete cover over reinforcing, use of alternate reinforcing, coatings, etc. Cathodic protection is also used to protect new and existing structures, and has a long history in marine and offshore structures. Cathodic protection will stop corrosion even in a salt contaminated structure.

SECTION 2. FUNDAMENTALS OF CATHODIC PROTECTION

Corrosion is an electrochemical reaction. Formation of a corrosion cell requires an anode, a cathode, oxygen, an ionic path and a metal path between the cathode and anode (Figure 9-1). The anodic site is the location of visible corrosion (oxidation), while the cathodic is the site of the reduction reaction driven by activity at the anode. The metallic path is provided by the steel member or reinforcing, and the water provides the ionic path. Oxygen is generally supplied from the atmosphere. The presence of salts or other electrolytes in the water facilitates the movement of electrons and increases the rate of corrosion.

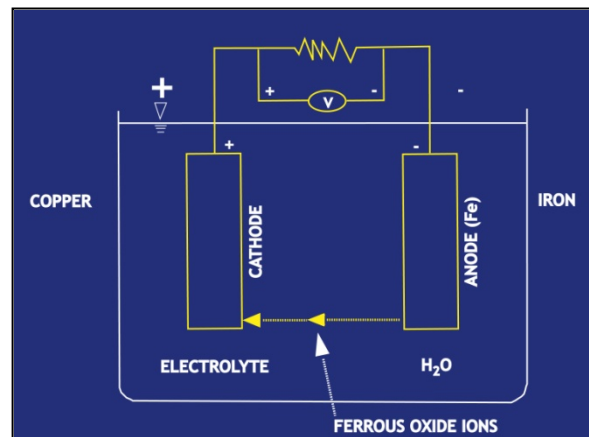

Figure 9-1 Electrochemical Corrosion Cell

Cathodic protection systems suppress corrosion activity by providing sufficient electrical current from an external source to exceed the corrosion threshold for the local environment, overcoming the on-going corrosion current in the structure. The anodic reaction stops, halting corrosion. Cathodic protection systems are classified as impressed current systems which use an external power source for current, or as galvanic systems which use current generated by a sacrificial anode such as zinc.

SECTION 3. CATHODIC PROTECTION SYSTEMS

9-3.1 Galvanic Systems

Galvanic systems operate on the basis of dissimilar metal corrosion and the relative position of specific metals in the Galvanic Series. When two metals are electrically connected, the metal with higher electrical potential (corrosion potential) will sacrifice itself to protect the other metal. Figure 9-2 is a partial list of electrical potentials of common metal. The material with the higher electrical potential is at the top.

Material	Electrical Potential (V)*
Zinc	-1.10
Carbon Steel	-0.68
Copper	-0.43
*All values with respect to copper-copper-sulfate half cell	

Figure 9-2 Partial List of Electrical Potentials

Galvanic systems work best in low resistivity electrolytes such as sea water since their driving voltage is limited.

Sacrificial anodes are typically made of zinc, aluminum, or magnesium. Zinc is the most common due to a combination of good performance and low cost. Aluminum anodes are alloyed with zinc. Magnesium anodes are poorly suited for use in sea water due to the tendency of magnesium to self-corrode in the low resistivity seawater. Zinc anodes are well-suited to the seawater environment when sufficient exposure to moisture maintains lower resistance and the availability of chloride ions keeps the zinc active.

Advantages and disadvantages of the galvanic system are shown in Figure 9-3.

Galvanic System	
<p>Advantages</p> <ul style="list-style-type: none"> Simple system No monitoring Limited maintenance Self-adjusts current output as structure's potential varies Minimal risk of hydrogen embrittlement on prestressing steel 	<p>Disadvantages</p> <ul style="list-style-type: none"> Limited anode life Limited current output

Figure 9-3 Advantages and Disadvantages of the Galvanic System

The simplicity and self-regulating aspects of the galvanic system make it attractive in sea water environments. Anode size and expected life can be calculated, but at some point, anode replacement may be required. Anodes should not be painted.

9-3.2 Impressed Current Systems

Impressed current systems drive a low voltage direct current from an inert anode through the electrolyte to the structure to be protected. Sufficient direct current is provided to overcome the anodic reaction on the steel surface. The direct current is supplied by an external power source. Figure 9-4 shows typical components of an impressed current system. When impressed current systems are used on steel structures, coatings should be used above and below the water. No cathodic protection is provided to those portions of the structure located above water.

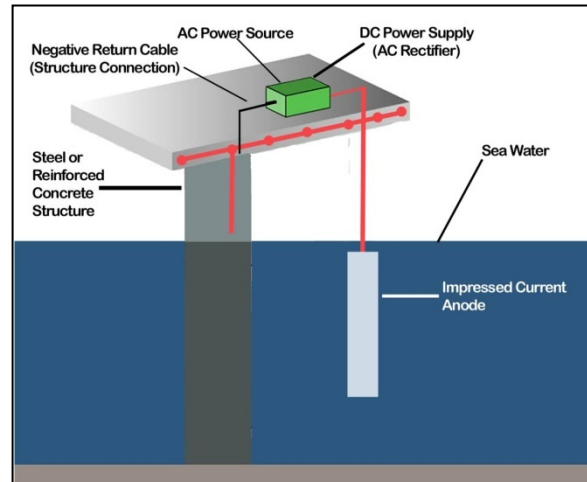

Figure 9-4 Impressed Current System

Power for impressed current systems has traditionally been supplied by commercial utilities as power run through a rectifier to produce direct current. Solar power and special batteries have also been used. Anodes are commonly made of cast iron, graphite, and special alloys. The negative side of the various protected components is connected back to a grounding system. Figure 9-5 shows a control cabinet and power source.

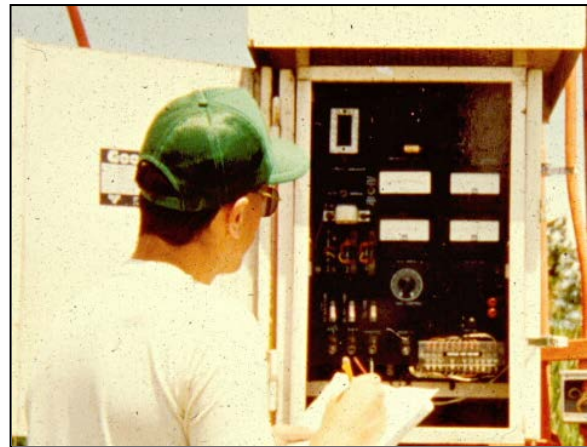

Figure 9-5 Control Cabinet

Impressed current systems must be regularly monitored and current output adjusted as needed. A higher current may be needed to initially polarize the structure. If the current is too high, there is a potential for hydrogen to be produced from the reduction of water into hydrogen and oxygen. The hydrogen may cause embrittlement of prestressing steel, resulting in steel cracking.

Figure 9-6 summarizes advantages and disadvantages of impressed current systems.

Impressed Current System	
Advantages	Disadvantages
<p>Applied current can be controlled and varied</p> <p>Can protect more extensive area</p> <p>Suitable for high resistivity electrolytes</p> <p>Requires fewer anodes than galvanic systems</p>	<p>Requires external power source</p> <p>Potential monthly power charges</p> <p>Initial costs higher than galvanic systems</p> <p>Requires regular adjustment and maintenance</p> <p>Anodes are long life</p>

Figure 9-6 Advantages and Disadvantages of the Impressed Current System

SECTION 4. EXAMPLE SYSTEMS

A variety of systems are supplied by different manufacturers. They generally fall into several categories such as piles jacket systems, surface applied systems, and embedded systems.

9-4.1 Pile Jacket-Anode Systems

Fiberglass pile jackets incorporating an integral zinc mesh sacrificial anode are used to rehabilitate and protect concrete piles in the tidal and splash zones (Figure 9-7). Prior to jacket installation loose concrete is removed, but no pile repairs are completed. The pile jacket/mesh system is installed and a sand cement grout used to fill the space between the pile and jacket. The grout absorbs water and provides a path for current flow from the mesh. A connection between the zinc mesh and pile reinforcing is made by a soldered or drill and tapped connection to the reinforcing steel or prestressing strands. Electrical continuity between reinforcing steel within the pile should be verified. In the case of prestressed piles, it may be necessary to electrically connect all the prestressing strands together.

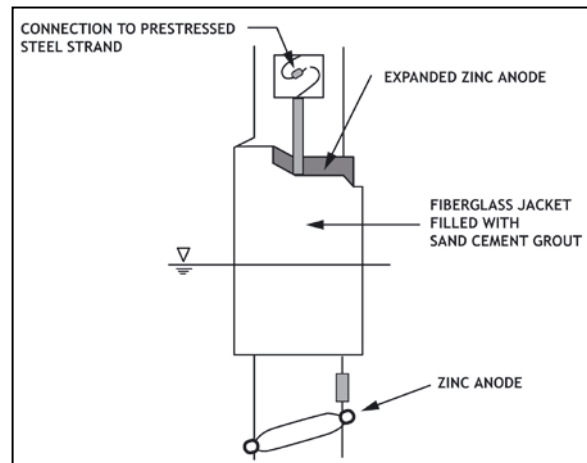

Figure 9-7 Zinc Mesh Pile Jacket

In order to preclude rapid depletion of the zinc mesh near the bottom of the jacket (attempting to protect the pile outside the jacket) a bulk 45-pound zinc anode is attached to the pile below the jacket. This anode must also be electrically connected

to the pile reinforcing steel or prestressing strands. Based upon tests conducted by the Florida Department of Transportation, the expected life of the system is more than 45 years.

9-4.2 Surface Applied Systems

9-4.2.1 Arc Sprayed Zinc

Arc sprayed zinc (Figure 9-8) has been used to protect concrete in splash zone and atmospheric zone applications. The sprayed zinc is applied directly over cleaned resurfacing steel, usually in periods of low tide, where deteriorated concrete has been removed. Performance is best where the concrete is wetted periodically. Arc sprayed Luminous Zinc - Indium alloy is installed in a similar manner, but has a higher current output. Arc sprayed zinc can be used as part of an impressed current system or as a galvanic system. The zinc thickness is typically 300 to 400 microns.

9-4.2.2 Titanium Mesh System

A titanium mesh impressed current system (Figure 9-9) can be installed over a patched concrete surface, normally in the tidal and splash zones. Power is supplied to mesh distributor bars from a power source on or near the bridge. The mesh is normally covered with sprayed conductive mortar after installation.



Figure 9-8 Application of Sprayed Zinc

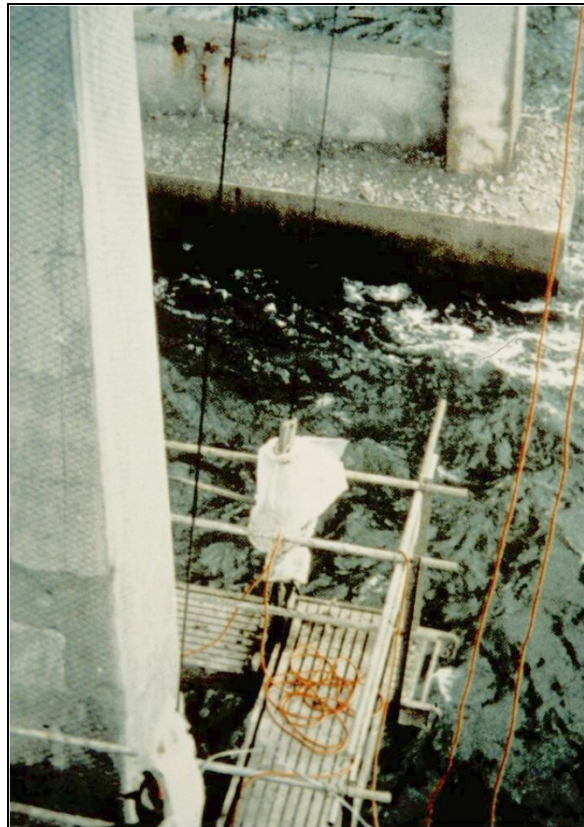

Figure 9-9 Titanium Mesh Installation

9-4.2.3 Zinc Sheets

Zinc sheets with a conductive adhesive backing can be applied to repaired concrete surfaces. The zinc sheet is typically 0.25 mm thick, and performs as a galvanic system.

9-4.3 Embedded Anode Systems

Embedded anode systems include galvanic and impressed current systems.

9-4.3.1 Impressed Current Systems

Impressed current systems using titanium ribbon or wires can be installed in slots cut into the concrete surface. The slots are filled with cementitious grout. Wire spacing is typically in the 8 to 20 inch range. Installation of the slots must not damage existing reinforcing.

9-4.3.2 Galvanic Systems

Embedded galvanic anodes can be installed in concrete repairs (Figure 9-10) or placed into a grid of drilled holes that are then filled with cementitious grout. Rod type anodes up to several feet long can be used in a grid pattern to protect steel in larger repairs.



Figure 9-10 Galvanic Sacrificial Embedded Anodes Along Edge of Repair

CHAPTER X CONTRACTING AND CONSTRUCTION INSPECTION

SECTION 1. INTRODUCTION

As bridge owners look for more economical repair options—in lieu of full bridge replacement—underwater construction becomes more prevalent. Many agencies are not versed in the methods of underwater construction and often times overlook the costs and issues associated with work below the waterline. Construction for underwater repairs differs from topside or dry work and involves equipment and repair methods that owners need to plan accordingly for.

SECTION 2. CONTRACTOR RISK

Underwater construction and work in the marine environment poses significantly more risk than working on land. In addition to higher construction costs, underwater construction is also more hazardous to the worker. Underwater contractors have one of the highest occupational fatality rates in the United States.

Various constraints on performing work are presented in Chapter V in the context of determining how work may be accomplished. All of these constraints produce risks with which the contractor must deal and account for when preparing project bids and schedules. Some of these may be determined with a fair degree of accuracy. For instance, tide tables can be used to determine available work periods where tidal currents are high. At best, many of the constraints such as vessel traffic, weather delays, permit delays, and others can only be estimated and, when taken in combination, may yield substantial risk.

Though information on some of these factors may not be available to those preparing contract documents, and others may depend on choices made by the contractor, it is important that all possible site and permit information be provided when soliciting bids for marine work. Providing the contractor with schedule flexibility, within reasonable project limits, may help mitigate some risk factors.

SECTION 3. INSURANCE

Insurance requirements become more complicated and expensive when the work involves underwater construction. Separate policies and riders are often required to provide additional coverage for underwater work that is not specifically covered with a primary policy. The following will address the different types of insurance involved

with underwater contractors and what owners need to consider. Certificates of insurance should be provided to the bridge owner for all policies in place.

10-3.1 Worker's Compensation

Worker's compensation is a no fault type of insurance that provides compensation and medical assistance for workers who are injured during the course of employment. It also pays death benefits to dependants for job-related injuries. All employers in the United States are required to carry worker's compensation insurance.

Diving contractors pay higher premiums than most contractors. Rates are based on amount of hours spent in the water by the contractor's divers. The insurance company underwriting the policy audits payroll records each year to determine rates. Rates for contractors providing diving services are usually 30-40 percent higher than typical above water service rates. Subsequently most diving contractors have wet pay and dry pay rates depending on the type of work.

10-3.2 Longshoreman's Insurance

United States Longshoreman's & Harbor Work Act (USL&H) is a federally mandated insurance put in place as a supplement to workers compensation to provide compensation to workers if they were injured or killed while working on navigable waters in the US. This also includes work on piers, wharfs, dry docks, or other adjoining structure to the waterway. More recently, the term "navigable waters" has also included almost any body of water. Owners should note that workers falling under jurisdiction of USL&H include all trades in addition to divers and support personnel. Determination of where Worker's Compensation and USL&H coverage apply is not always clear. USL&H insurance should be a requirement for all underwater repair contracts.

10-3.3 Jones Act Maritime

The Jones Act is similar to Worker's Compensation and USL&H except that it provides coverage for the crews of vessels. There has always been discussion as to what constitutes a vessel and who is designated as a crew member. Divers working from barges and jack-up vessels have been classified as coming under the Jones Act.

Most companies obtain Marine Employers Liability insurance to comply with the Jones Act. This insurance is normally under separate policy, and should be required of contractors engaged in marine repair projects.

SECTION 4. CONTRACT DOCUMENTS AND ADMINISTRATIVE

In addition to the standard information normally provided on repair documents, the drawings and specifications should address special concerns that differ from the dry

or topside work. Since underwater work often doesn't involve standard details, the owner needs to ensure that all work performed underwater is communicated in detail on the design drawings and in the specifications. A significant amount of effort may be required when writing the specifications of special provisions to cover the particular project requirements.

10-4.1 Drawings and Specifications

Drawings and specifications must clearly establish the repair requirements as determined by the bridge owner's engineers. The extent of repair and selected repair method should be indicated, along with appropriate details. In establishing the extent of repair, consideration should be given to the date of the design basis inspection report and the potential increase in deterioration until the repairs are actually performed. An allowance of perhaps 20 percent additional removal for concrete structures is included by some engineers to account for expected additional deterioration even when thorough and recent inspection data is available.

When particular construction sequences or temporary support may be needed, these should be shown along with a construction sequence. For instance, it may be a constraint that only one pile in a multi-pile bent can be under repair at any one time.

Contract documents should include all available site and environmental information and detail special requirements for materials and testing, environmental compliance tests, and construction inspection. Specialized information to be provided when available could include:

- Water depths and fluctuations
- Current data
- Water quality data
- River channel bottom materials
- Water access points or staging areas.

10-4.2 Diving Submittals

In addition to the contractor's normal project information submittals, additional documents should be required which are associated directly with the diving operation. The owner should require the diving contractor to submit the following additional documents:

- Project Execution Plan—The project execution plan is prepared prior to execution of the work. From the definable tasks of the contract documents, the contractor

should outline in details how the work is accomplished. It should address the following:

- Project description
 - Project organization
 - Safety
 - Operations
 - Submittal requirements
 - Schedule
- Injury Management and Accident Prevention Plan—The injury management and accident prevention plan outlines the contractor’s policies and procedures for work place accidents. It should address the following:
 - Injury Protocol
 - Procedures for providing emergency health care
 - Procedures for reporting injuries
 - List nearby hospital locations and hyperbaric treatment facilities
 - List points of contact and Safety Officer
 - Discussion of the work specific to the project and how work will be performed safely
 - Job Safety and Environmental Analysis—The job safety and environmental analysis (JSEA) is a document prepared prior to diving operations on a daily basis. JSEAs address safety issues and plan out individual tasks, identify hazards, and outline the techniques to mitigate the risk.

10-4.3 Prequalifications and Safety

Because of the complex nature and safety concerns of underwater construction, owners may wish to establish a prequalification list based on normal agency requirements. As an added check, owners should require contractors to submit copies of their Save Dive Practices Manual. When identifying qualified contractors, owners should consider the following:

- OSHA safety record including TRIR and EMR ratings
- Financial strength and class rating
- Experience of proposed staff, particularly site engineers and job foreman
- Equipment type and quantity owned by the contractor

SECTION 5. PERMITS

10-5.1 General

Generally, permits are not required for underwater inspection work unless destructive testing is taking place. However, construction permits are normally required for underwater repairs, demolition, or dredging. In areas where sensitive environments exist, it is often required to perform a benthic survey and environmental assessment, this information is submitted for approval by the Environmental Protection Agency (EPA) in accordance with National Environmental Policy Act (NEPA). Several agencies must sign off on the NEPA package submittal such as state and local EPA agencies, U.S. Department of Interior Fish and Wildlife Service and U.S. Army Corp of Engineers. At least 90 days or longer should be allowed for the permit approval process.

10-5.2 Owner Provided

The owner normally provides the environmental and dredging permits if required. The contractor is typically not experienced in the NEPA permitting process. NEPA permitting is best handled by the owner unless the required permits relate directly to the contractor's diving operation or safety plan.

Other permits may be required from the U.S. Army Corps of Engineers, such as the 404 Permit, or from the U.S. Coast Guard. When permits are obtained by the owner, the process can be initiated early in the repair design phase and the overall project time is reduced.

10-5.3 Contractor provided

The contractor should normally supply any required diving related permits and general construction permits. Some of these include:

- Local jurisdiction diving permits from local law enforcement or USCG or other local agency
- Permits from USCG for navigation
- Site surveys involving buried utilities and locations

SECTION 6. PAYMENT

10-6.1 Unit Prices

Lump sum and unit price contracts both have advantages and disadvantages. A lump sum contract can benefit the owner if the scope is clearly defined, and environmental

factors or unforeseen conditions do not affect the overall costs. Contractors often times take advantage of these type of contracts to request additional compensation if the scope is not defined clearly. Unit price contracts are often necessary for this type of work because they provide for an adequate way to facilitate and control the cost of variables and items that are unable to be clearly defined prior to execution. Unit price contracts enable cost over/under runs to adjusted and provide a uniform basis for contractor bids.

10-6.2 Mobilization and Demobilization

Mobilization and demobilization is often overlooked on budgeting for marine or repair projects. These costs often represent up to 15 to 20 percent of the total project costs depending on the type of work involved. It should be noted that mobilization and demobilization costs are usually lump sum unit prices and that the contractor will invoice these at the point mobilization or demobilization commence.

In addition to mobilization and demobilization cost, owners should be aware of the contractor's requirements to stage dive related and construction related equipment. Diving equipment may require space for a dive control van utilizing 40 foot long shipping containers or a mobile dive unit consisting of a van type truck 20 to 30 feet long. Staging area for compressors, chambers, high pressure gas bottles, and air volume tanks should also be accounted for. Construction equipment may consist of mobile truck cranes, hydraulic and welding units, and material storage areas requiring protection from the weather.

Owners should budget and plan for the following:

- a. Mobilization—Including all activities and costs for transportation of equipment, personnel and materials to the site. In addition, it should include costs related to field offices, utility hook ups and other facilities necessary for the operations.
- b. Equipment Staging—Typical area requirements for surface supplied diving operations when repairing a large bridge include approximately 700-1000 square feet. In addition, temporary security fencing may be required. Dry storage also may be required to protect construction materials from the weather.
- c. Demobilization—Including all activities and costs for transportation of equipment, personnel, materials from the site, disposal of hazardous materials, removal of temporary field offices and clean-up.

SECTION 7. CONSTRUCTION INSPECTIONS

10-7.1 Inspection Options

To ensure quality in the construction process the owner should implement a program to oversee the enforcement of the construction documents. There are several ways to accomplish this for underwater repair projects. The owner can utilize in-house inspections, contractor provided inspections, or inspections through the owners consultant. There are advantages and disadvantages to each option.

a. Contractor Provided Inspections

The owner may write the contract so that the contractor has full responsibility for the quality control and the inspections during and after construction. The advantage to this is that the owner has only one firm to go to in the event that problems arise. There are times when the owner does not have many options and must hire the contractor to inspect his/her own work if other diving sources are limited due to geographical area or other circumstances. However, this also puts the contractor in control of construction techniques and procedures that might enable him to compromise the quality of work if schedule or costs become critical.

b. Owner Provided Inspections

Many government agencies utilize internal resources to provide in-house inspections. The obvious advantage to this option is that the owner can ensure quality construction and is able to work closely with the contractor to ensure all requirements of the construction documents are fully met. In many cases, though, the agency does not have the in-house capability to conduct the underwater inspection portion of the work.

c. Consultant Provided Inspections

Using the design consultant or an outside consultant to oversee the construction inspection may offer some advantages and is becoming more common. The owner may retain a consultant with the resources in-house to provide full time or part time inspection services for both the above and below water portions of the project.

d. Combination Inspections

The owner may provide a resident engineer and above water inspection and materials testing services, and retain a consultant with in-house inspection divers to oversee the underwater portions of the work. The inspection divers then operate as an extension of the owner's inspection effort.

10-7.2 Inspection Scope

The owner should specify prior to execution of the contract the amount of time allotted for inspections. Full-time inspection is always desirable if the project budget is able to support the additional costs. Part-time and milestone inspections are more common since the project may not always warrant full time inspections. Regardless of the type of inspection used, it is important that the owner plan for the following:

- Preconstruction inspection to document existing conditions
- Verification inspections during construction
- Final acceptance inspection
 - a. Full-Time—Some projects require the use of full-time inspection due to the nature and cost of the work. Many owners will utilize full-time inspection if the project is large, has an aggressive schedule and the onsite work is critical. Most work requires the inspector to be on site at all times during construction, especially if the contractor is placing concrete underwater several times a week and there are multiple tasks being accomplished concurrently with other work.
 - b. Part-time—If much of the work is being performed underwater, the owner may consider part-time inspections. Part-time inspections are normally scheduled ahead of time before the project starts. The inspector is typically scheduled to be on-site during the same times each week. Part-time inspections are adequate if the work is repetitive and no critical items affect the quality. Usually these work tasks are long duration and the inspector is able to maintain the set schedule without missing key elements to inspect. For underwater repairs, part-time inspections are not typically used as milestone inspections.
 - c. Milestone Inspections—For many underwater repair projects, milestone inspections are advantageous for all parties involved in the construction. Construction or repair work taking place underwater is not as efficient as topside work might be. Therefore, a significant amount of time is spent on preparation and setup by the contractor. The contractor and owner can schedule milestone inspections at critical hold points during the construction. Milestone inspections are favorable in that they can also be scheduled in advance and adjusted to not interrupt construction. In addition, milestone inspections provide a cost savings to the owner without sacrificing quality.

10-7.3 Above Water Inspection

In setting up the above water inspection, the contract documents should be reviewed for items unique to underwater repairs. The resident engineer must be familiar with

this project requirements and schedule meeting to review them with the contractor and the inspection staff. Some of the issues which may need to be addressed include the following:

- Repairs may utilize prepackaged grouts, mortars, or other materials. Proper storage must be provided so these materials are not damaged, especially by water which tends to be everywhere on a marine project.
- Materials submittals for special materials, concrete mixes, etc. must be submitted ahead for review. Laboratory testing may be required.
- On-site concrete batching facilities must be inspected and certifications reviewed prior to use.
- Detailed procedures for concrete placements should be required. This should include material transport methods and time and placement rate charts.
- Special test methods and equipment may be needed, and agency or consultant staff may need additional training/certification. Examples could include grout strength and flow tests, on site testing for high slump mixes using a flow table, pull-off testing of pile jackets, and so forth.

10-7.4 Inspection Checklists

Various inspection criteria for repairs are presented in the chapters covering particular repair procedures and techniques. Two of the most common repair techniques involve concrete repair and pile repair. A summary list of inspection items for these is provided below.

- a. Concrete Repairs
 - Compliance with drawings and specifications
 - Preconstruction inspection to verify existing conditions
 - Prepour inspections
 - Formwork and reinforcing observations
 - Concrete cleaned and surface properly prepared
 - Adequate reinforcing supports/chairs
 - Tolerance verifications
 - Formwork cleanouts installed
 - Debris and marine growth removal
 - Formwork mortar tight fit-up
 - Concrete removal verifications

b. Pile Jacketing

- Compliance with drawings and specifications
- Pile jackets and hardware meet specifications
- Hardware is properly installed
 - Epoxy grout equipment submittals to ensure specifications are met
 - Grout mixture has proper flow and strength tests submitted
 - Pile adequately cleaned and prepared; marine growth and flash rust (steel) are critical considerations
 - Grout ports are clear and in proper location
 - Jacket properly installed to contain hoop stresses
 - Standoffs in correct location, equally spaced and sufficient quantity
 - Top and bottom seals in place
 - Chloride flush from bottom up to remove chlorides from salt water
 - Pours should take place within 24 hours of cleaning
 - Grout from bottom up
 - Monitor jackets with tell tales for alignment during pouring of grout
 - Push for five-year warranty for normal service

10-7.5 Acceptance Inspection and NBI Update

To ensure all construction has met the contract document requirements, the owner should require or perform an acceptance inspection. An acceptance inspection is the final inspection after all punch list items have been completed. This inspection is performed before the final walk-through, and should include a thorough inspection of the construction work. The owner should require the contractor to submit a request at least one week in advance of the site acceptance inspection. The inspection agency with the owner's representative should perform the acceptance inspection. An acceptance inspection should include the following:

- Contractor-submitted certification of construction completion
- Original record drawings signed and sealed by the Engineer of Record
- "As-built" drawings signed and sealed by the Engineer of Record
- Any test reports signed and sealed by the Engineer of Record
- Update NBI or element level ratings (if applicable) and other internal bridge forms

GLOSSARY

A

Abutment. A substructure unit composed of stone, concrete, brick, or timber supporting the end of a single span or the extreme end of a multispan superstructure, and, in general, retaining or supporting the approach embankment placed in contact therewith. (See also WING WALL.)

Acid Copper Chromate (ACC). Gives wood protection from decay and termite attack but may be susceptible to attack by some copper-tolerant fungi.

Aggregate. The sand, gravel, broken stone, or combinations thereof with which the cementing material is mixed to form a mortar or concrete. The fine material used to produce mortar for stone and brick masonry and for the mortar component of concrete is commonly termed "fine aggregate" while the coarse material used in concrete only is termed "coarse aggregate".

Ammoniacal Copper Arsenate (ACA). Outdated version of ACZA without zinc.

Ammoniacal Copper Zinc Arsenate (ACZA). Protects wood from attack by decay fungi, insects, and most types of marine borers.

Anode. A metallic surface on which oxidation occurs, giving up electrons with metal ions going into solution or forming an insoluble compound of the metal.

Anti-washout Admixture (AWA). A concrete admixture that reduces the loss of fine materials from concrete when placed in water.

Arc Welding. Uses a welding power supply to create an electric arc between an electrode and the base material to melt the metals at the welding point. The welding region is sometimes protected by a shielding gas and/or an evaporating filler material.

B

Bank. The sides of a channel between which the flow is normally confined.

Base Metal, Structure Metal, Parent Metal. The metal at and closely adjacent to the surface to be incorporated in a welded joint which will be fused, and by coalescence and interdiffusion with the weld will produce a welded joint.

Batter. The inclination of a surface in relation to a horizontal or vertical plane or occasionally in relation to an inclined plane. Batter is commonly designated upon bridge detail plans as so many inches to one foot.

Batter Pile. A pile driven in an inclined position to resist forces which act in other than a vertical direction. It may be computed to withstand these forces or, instead, may be used as a subsidiary part or portion of a structure to improve its general rigidity.

Bed. The bottom of the channel bounded by banks.

Bent. A supporting unit of a trestle or a viaduct type structure made up of two or more column or column-like members connected at their topmost ends by a cap, strut, or other member holding them in their correct positions. This connecting member is commonly designed to distribute the superimposed loads upon the bent, and when combined with a system of diagonal and horizontal bracing attached to the columns, the entire construction functions somewhat like a truss distributing its loads into the foundation.

When piles are used as the column elements, the entire construction is designated a "pile bent" and, correspondingly, when those elements are framed, the assemblage is termed a "frame bent."

Bottom Time. The total elapsed time measured in minutes from the time when the diver leaves the surface in descent to the time that the diver begins ascent.

Bracing. A system of tension or compression members, or a combination of these, forming with the part or parts to be supported or strengthened, a truss or frame. It transfers wind, dynamic, impact, and vibratory stresses to the substructure and gives rigidity throughout the complete assemblage.

C

Cap. (Cap Beam, Cap Piece.) The topmost piece or member of a viaduct, trestle, or frame bent serving to distribute the loads upon the columns and to hold them in their proper relative positions.

The topmost piece or member of a pile bent in a viaduct or trestle serving to distribute the loads upon the piles and to hold them in their proper relative positions.

Cathode. A surface that accepts electrons and does not corrode.

Cement Paste. The plastic combination of cement and water that supplies the cementing action in concrete.

Cement Matrix. The binding medium in a mortar or concrete produced by the hardening of the cement content of the mortar, concrete mixture of inert aggregates, or hydraulic cement and water.

Channel. The bed and banks that confine the surface flow of a stream.

Chromated Copper Arsenate (CCA). A chemical wood preservative used in pressure treated wood to protect from rotting due to insects and microbial agents.

Clay. Natural mineral material having plastic properties and composed of very fine particles; the clay mineral fraction of a soil is usually considered to be the portion consisting of particles finer than 2µm; clay minerals are essentially hydrous aluminum silicates or occasionally hydrous magnesium silicates.

Coating. 1) Material applied to a surface by brushing, dipping, mopping, spraying, troweling, etc., to preserve, protect, decorate, seal, or smooth the substrate. 2) Material used to protect a concrete surface from atmospheric contaminants and those that penetrate slightly and leave a visible clear or pigmented film on the surface.

Cofferdam. In general, an open box-like structure constructed to surround the area to be occupied by an abutment, pier, retaining wall or other structure and permit unwatering of the enclosure so that the excavation for the preparation of a foundation and the abutment, pier, or other construction may be effected in the open air. In its simplest form, the dam consists of interlocking steel sheet piles.

Commercial Diver. A person who receives remuneration for diving activities.

Concrete. A composite material consisting essentially of a binding medium within which are embedded particles or fragments of a relatively inert mineral filler. In portland cement concrete, the binder or matrix, either in the plastic or the hardened state, is a combination of portland cement and water. The filler material, called aggregate, is generally graded in size from fine sand to pebbles or stones which may, in some concrete, be several inches in diameter.

Consolidation. The time-dependent change in volume of a soil mass under compressive load caused by pore-water slowly escaping from the pores or voids of the soil. The soil skeleton is unable to support the load by itself and changes structure, reducing its volume and usually producing vertical settlements.

Copper Naphthenate. An effective wood treatment used to protect from wood-destroying fungi and insects. It is water repellent, leach resistant, and has a high degree of fixation to wood fibers.

Corrosion. Destruction of metal by a chemical, electrochemical, or electrolytic reaction within its environment.

Countermeasure. A measure intended to prevent, delay, or reduce the severity of hydraulic problems.

Crack. A complete or incomplete separation, of either concrete or masonry, into two or more parts produced by breaking or fracturing.

Cracking. 1) Map Cracking- intersecting cracks that extend below the surface of hardened concrete; caused by shrinkage of the drying surface concrete that is restrained by concrete at greater depths where either little or no shrinkage occurs; vary in width from fine and barely visible to open and well-defined. 2) Shrinkage-cracking of a structure or member due to failure in tension caused by external or internal restraints as reduction in moisture content develops, carbonation occurs, or both.

Creep. An inelastic deformation that increases with time while the stress is constant.

Creosote. A wood preservative derived from tar used for commercial purposes only. It is used as a fungicide, insecticide, miticide, and sporicide to protect wood and is applied by pressure methods to wood products, primarily utility poles and railroad ties.

Cribbing. A construction consisting of wooden, metal or reinforced concrete units so assembled as to form an open cellular-like structure for supporting a superimposed load or for resisting horizontal or overturning forces acting against it.

Cross Section. A section normal to the trend of a channel or flow.

Current. Water flowing through a channel.

Cylinder. A pressure vessel for the storage of gases.

D

Debris. Any material including floating woody materials and other trash, suspended sediment, or bed load, moved by a flowing stream.

Degradation. General, progressive lowering of the stream channel by erosion.

Deterioration. Physical manifestation of failure of a material (for example, cracking, delamination, flaking, pitting, scaling, spalling, and staining) caused by environmental or internal autogenous influences on rock and hardened concrete as well as other materials. Or decomposition of material during either testing or exposure to service.

Dike. An impermeable linear structure for the control or containment of overbank flow. A dike-trending parallel with a streambank differs from a levee in that it extends for a much shorter distance along the bank, and it may be surrounded by water during floods.

Dimension Stone. A stone of relatively large dimensions, the face surface of which is either chisel or margin drafted but otherwise rough and irregular; commonly called either "rock face" or "quarry face."

Stones quarried with the dimension large enough to provide cut stones with given finished dimensions.

Discharge. Volume of water passing through a channel during a given time.

Diver. An employee engaged in work using underwater apparatus which supplies compressed breathing gas at ambient pressure from a self-contained or remote source.

Dolphin. A group or cluster of piles driven in one to two circles about a center pile and drawn together at their top ends around the center pile to form a buffer or guard for the protection of channel span piers or other portions of a bridge exposed to possible injury by collision with waterbound traffic. The tops of the piles are secured with a wrapping consisting of several plies of wire, rope, coil, twist link, or stud link anchor chain, which, by being fastened at its ends only, renders itself taut by the adjustments of the piles resulting from service contact with ships, barges, or other craft. The center pile may project above the others to serve as a bollard for restraining and guiding the movements of water-borne traffic units. Single steel and concrete piles of large size may also be used as dolphins.

Drilled Shafts. Provide deep foundations for building, bridges, and retaining walls.

Driven Piles. Prefabricated piles that are driven into the ground using a pile driver. The soil displaced by driving the piles compresses the surrounding soil, causing greater friction against the sides of the piles, thus increasing their load-bearing capacity.

Dry Suit (variable volume). A diving suit capable of being inflated for buoyancy or insulation which keeps the diver's body essentially dry.

E

Ebb Tide. Flow of water from the bay or estuary to the ocean.

Electrolyte. Moisture or a liquid carrying ionic current between two metal surfaces, the anode and the cathode.

Element. Metal Structures. An angle, beam, plate or other rolled, forged or cast piece of metal forming a part of a built piece. For wooden structures, a board, plank, joist, or other fabricated piece forming a part of a built piece.

Epoxy. A synthetic resin which cures or hardens by chemical reaction between components which are mixed together shortly before use.

Erosion. Progressive disintegration of a solid by abrasion or cavitation of gases, liquids, or solids in motion.

F

Fender. 1. A structure placed at an upstream location adjacent to a pier to protect it from the striking force, impact and shock of floating stream debris, ice floes, etc. This structure is sometimes termed an “ice guard” in latitudes productive or lake and river ice to form ice flows. 2. A structure commonly consisting of dolphins, capped and braced rows of piles, or wooden cribs either entirely or partially filled with rock ballast, constructed upstream and downstream from the center and end piers (or abutments) of a fixed or movable superstructure span to fend off water-borne traffic from collision with these substructure parts, and in the case of a swing span, with the span while in its open position.

Fender Pier. A pier-like structure which performs the same service as a fender but is generally more substantially built. These structures may be constructed entirely or in part of stone or concrete masonry.

Fill. (Filling.) Material, usually earth, used for the purpose of raising or changing the surface contour of an area, or for constructing an embankment.

Filler Metal. Metal prepared in wire, rod, electrode or other adaptable form to be fused with the structure metal in the formation of a weld.

Flood Tide. Flow of water from the ocean to the bay or estuary.

Flux-cored Arc Welding (FCAW). A semi-automatic or automatic welding process that requires a continuously-fed consumable tubular electrode contain a flux which usually produces the necessary protection from the atmosphere. It is fast and portable.

Footing. (Footing Course, Plinth.) The enlarged, or spread-out lower portion of a substructure, which distributes the structure load either to the earth or to supporting piles. The most common footing is the concrete slab, although stone piers also utilize footings. Plinth refers to stone work as a rule. “Footer” is a local term for footing.

Forms. (Form Work, Lagging, Shuttering.) The constructions, either wooden or metal, providing means for receiving, molding and sustaining in position the plastic mass of concrete placed therein to the dimensions, outlines and details of surfaces planned for its integral parts throughout its period of hardening.

The terms “forms” and “form work” are synonymous. The term “lagging” is commonly applied to the surface shaping areas of forms producing the intradoses of arches or other curved surfaces, especially when strips are used.

Foundation. The supporting material upon which the substructure portion of a bridge is placed. A foundation is “natural” when consisting of natural earth, rock or near-rock material having stability adequate to support the superimposed loads without lateral displacement or compaction entailing appreciable settlement or deformation. Also, applied in an imprecise fashion to a substructure unit.

Pile or Piled Foundation. A foundation reinforced by driving piles in sufficient number and to a depth adequate to develop the bearing power required to support the foundation load.

Fresh Water. Water that is not salty as compared to sea water which generally has a salinity of 35,000 parts per million.

FSW. A foot of seawater; a unit of pressure generally defined as 1/33 of a standard atmosphere, which represents the pressure exerted by a foot of seawater having a specific gravity of 1.027, equal to approximately .445 pounds per square inch.

G

Gas Tungsten Arc Welding (GTAW). An arc welding process that uses a nonconsumable tungsten electrode to produce the weld.

Gravel. A rock fragment whose diameter ranges from 2 to 64 mm.

Grout. 1) A mortar having a sufficient water content to render it a free-flowing mass, used for filling (grouting) the interstitial spaces between the stones or the stone fragments (spalls) used in the “backing” portion of stone masonry; for fixing anchor bolts and for filling cored spaces in castings, masonry, or other spaces where water may accumulate. 2) A fluid mixture of cement and water or of cement, sand, and water used to fill joints and voids.

H

Head. A measure of water pressure expressed in terms of an equivalent weight or pressure exerted by a column of water. The height of the equivalent column of water is the head.

Helmet. (open-circuit and/or surface-supplied). Breathing and protective equipment which encloses the diver’s head.

J

The Jones Act. Requires that all goods transported by water between U.S. ports be carried in U.S. flag ships, constructed in the U.S., owned by U.S. citizens, and crewed wholly by U.S. citizens.

L

Local Scour. Removal of material from around piers, abutments, spurs, and embankments caused by an acceleration of flow and resulting vortices induced by obstructions to the flow.

M

Masonry. A general term applying to abutments, piers, retaining walls, arches and allied structures built of stone, brick or concrete and known correspondingly as stone, brick or concrete masonry.

Mattress. A blanket or revetment of materials interwoven or otherwise lashed together and placed to cover an area subject to scour.

Micropiles. Small diameter piles that are installed by drilling and can be used in almost any type of ground where piles are required.

Mortar. An intimate mixture, in a plastic condition, of cement, or other cementitious material with fine aggregate and water, used to bed and bind together the quarried stones, bricks, or other solid materials composing the major portion of a masonry construction or to produce a plastic coating upon such construction.

The indurated jointing material filling the interstices between and holding in place the quarried stones or other solid materials of masonry construction. Correspondingly, this term is applied to the cement coating used to produce a desired surface condition upon masonry constructions and is described as the "mortar finish," "mortar coat," "floated face or surface," "parapet," etc.

The component of concrete composed of cement, or other indurating material with sand and water when the concrete is a mobile mass and correspondingly this same component after it has attained a rigid condition through hardening of its cementing constituents.

N

Nonstructural Repair. Halting or slowing deterioration without intending to affect the structural capacity of a member.

P

Pentachlorophenol. Before restrictions it was one of the most widely used biocides in the U.S. It was used as a herbicide, defoliant, mossicide, and as a disinfectant.

Pier. A structure composed of stone, concrete, brick, steel or wood and built in shaft or block-like form to support the ends of the spans of a multi-span superstructure at an intermediate location between its abutment.

The following types of piers are adapted to bridge construction. The first three are functional distinctions, while the remaining types are based upon form or shape characteristics.

Pier Cap. (Pier Top.) The topmost portion of a pier. On rigid frame piers, the term applies to the beam across the column tops. On hammerhead and tee piers, the cap is a continuous beam.

Pile. 1) An elongated member, usually made of timber, concrete, or steel, that serves as a structural component of a river-training structure. 2) A rod or shaft-like linear member of timber, steel, concrete, or composite materials driven into the earth to carry structure loads thru weak strata of soil to those strata capable of supporting such loads. Piles are also used where loss of earth support due to scour is expected.

Pile Pier or Bent. A pier composed of driven piles capped or decked with a timber grillage, concrete cap, or steel beam; or with a reinforced concrete slab forming the bridge seat.

Sheet Piles. Commonly used in the construction of bulkheads, cofferdams, and cribs to retain earth and prevent the inflow of water, liquid mud, and fine grained sand with water, are of three general types, viz.: (1) Timber composed of a single piece or of two or more pieces spiked or bolted together to produce a compound piece either with a lap or a tongued and grooved effect. (2) Reinforced concrete slabs constructed with or without lap or tongued and grooved effect. (3) Rolled steel shapes with full provision for rigid interlocking of the edges.

Pile Cap. Concrete footings for a pier or abutment supported on piles. Also applied to the concrete below the pile tops when footing reinforcing steel is placed completely above the piles.

Pile Jacket. A durable alternative to pile replacement to re-establish the strength of deteriorated concrete, steel or wooden piling.

Pile Splice. One of the means of joining one pile upon the end of another to provide greater penetration length.

Piling. (Sheet Piling.) General terms applied to assemblages of piles in a construction.

Preservation. (a.k.a. Preventive Maintenance) Actions to extend the life of a facility, typically without adding structural capacity.

Pressure. Force per unit of area. In diving, pressure denotes an exposure greater than surface pressure (1 ATM).

R

Rehabilitation. Work required to restore the structural integrity and address major safety defects of a facility.

Repair. To replace or correct deteriorated, damaged or faulty materials, components, or elements of a structure.

Repair Systems. The combination of materials and techniques used in the repair of a structure.

Replacement. Renew to a new facility.

Revetment. Rigid or flexible armor placed to inhibit scour and lateral erosion.

Rip rap. 1) Brickbats, stones, blocks of concrete or other protective covering material of like nature deposited upon river and stream beds and banks, lake, tidal or other shores to prevent erosion and scour by water flow, waves or other movement. 2) Layer or facing of rock or broken concrete dumped or placed to protect a structure or embankment from erosion; also the rock or broken concrete suitable for use. Rip rap has also been applied to almost all kinds of armor, including wire-enclosed rip rap, grouted rip rap, sacked concrete, and concrete slabs.

S

Sand. A rock fragment whose diameter is in the range of 0.062 to 2.0 mm.

Scour. 1) An erosion of a river, stream, tidal inlet, lake or other water bed area by a current, wash or other water in motion, producing a deepening of the overlying water, or a widening of the lateral dimension of the flow area. 2) Erosion of streambed or bank material due to flowing water; often considered as being localized. See localized scour.

Scuba Diving. A diving mode independent of surface supply in which the diver uses open circuit self-contained underwater breathing apparatus.

Sealing. Applying a liquid to the surface of hardened concrete to either prevent or decrease the penetration of liquid or gaseous media such as water, aggressive solutions, and carbon dioxide.

Sediment. Fragmental material transported, suspended, or deposited by water.

Sheet Piling. (Sheeting.) A general or collective term used to describe a number of sheet piles taken together to form a crib, cofferdam, bulkhead, etc.

Shielded metal arc welding (SMAW). A manual arc welding process that uses a consumable electrode coated in flux to lay the weld. As the weld is laid, the coating gives off vapors to serve as a shielding gas to protect the weld area from atmospheric contamination.

Silt. Very finely divided siliceous or other hard and durable rock material derived from its mother rock through attritive or other mechanical action rather than chemical decomposition. In general, its grain size shall be that which will pass a Standard No. 200 sieve.

Slope. A term commonly applied to the inclined surface of an excavated cut or an embankment.

Slope Pavement. (Slope Protection.) A thin surfacing of stone, concrete or other material deposited upon the sloped surface of an approach cut, embankment or causeway to prevent its disintegration by rain, wind or other erosive action.

Spall. A fragment, usually in the shape of a flake, detached from a larger mass by a blow, by the action of weather, by pressure, or by expansion within the larger mass; a small spall involves a roughly circular depression not greater than 20 mm in depth and 150 mm in any dimension; a large spall may be roughly circular or oval or in some cases elongate and is more than 20 mm in depth and 150 mm in greatest dimension.

Splash Zone. An area on an offshore structure that is regularly wetted by seawater but is not continuously submerged. Metal in the splash zone must be well protected from the corrosive action of seawater and air.

Spread Footing. A pier or abutment footing that transfers load directly to the earth.

Stem. The vertical wall portion of an abutment retaining wall, or solid pier.

Stone Rip rap. Natural cobbles, boulder, or rock dumped or placed as protection against erosion.

Stream. A body of water that may range in size from a large river to a small rill flowing in a channel. By extension, the term is sometimes applied to a natural channel or drainage course formed by flowing water whether it is occupied by water or not.

Strengthening. Increasing the load-carrying capacity of a structural component beyond its current capacity or restoring a damaged structural component to its original design capacity.

Structural Repair. A repair that addresses deterioration and re-establishes or enhances the structural capacity of a member.

Substructure. The abutments, piers, grillage or other constructions built to support the span or spans of above water or from a bell, with compressed air for breathing.

Sulfate Attack. Either a chemical reaction, physical reaction, or both between sulfates usually in soil or ground water and concrete or mortar; the chemical reaction is primarily with calcium aluminate hydrates in the cement-paste matrix, often causing deterioration.

Surface Preparation. The removal of deteriorated or contaminate concrete or steel using a method or combination of methods to roughen or clean the substrate to enhance bond of a repair material or protective coating.

T

Tremie. A pipe extending below water, generally with a funnel-shaped top, through which concrete can be deposited.

V

Velocity. The time rate of flow usually expressed in m/s (ft/sec). The average velocity is the velocity at a given cross section determined by dividing discharge by cross-sectional area.

Volume Tank. A pressure vessel connected to the outlet of a compressor and used as an air reservoir.

W

Waterway. The available width for the passage of stream, tidal or other water beneath a bridge, if unobstructed by natural formations or by artificial constructions beneath or closely adjacent to the structure. For a multiple span bridge the available width is the total of the unobstructed waterway lengths of the spans.

Work Site. A vessel or surface structure from which dives are supported and/or the underwater location where work is performed.

ACRONYMS

AC - Alternating Current
ACI - American Concrete Institute
ASR - Alkali-Silica Reaction
ASTM - ASTM International (Previously American Society for Testing and Materials)
AWA - Antiwashout Admixture
AWPA - American Wood Preservers Association
AWS - American Welding Society
CE - Carbon Equivalent
CP - Cathodic Protection
DC - Direct Current
DEF - Delayed Ettringite Formation
E - Modulus of Elasticity
EPA - Environmental Protection Agency
FCAW - Flux Cored Arc Welding
FHWA - Federal Highway Administration
FRP - Fiber Reinforced Polymers
GTAW - Gas Tungsten Arc Welding
ksi - Kips Per Square Inch
MHW - Mean High Water
MIC - Microbiologically Induced Corrosion
MLW - Mean Low Water
NACE - NACE International (Formerly National Association of Corrosion Engineers)
NBI - National Bridge Inventory
NHI - National Highway Institute
OSHA - Occupational Safety and Health Administration
pcy - Pounds Per Cubic Yard
PPA - Preplaced Aggregate Concrete
psi - Pounds Per Square Inch
SMAW - Shielded Manual Arc Welding
USACE - U. S. Army Corp of Engineers